

Purchaser's Reference Information

IT IS IMPERATIVE THAT YOU FILL IN THE FOLLOWING INFORMATION AND REFER TO IT SHOULD THE NEED FOR SERVICE ARISE.

Product Name: Diamondback 900Ub Upright or 900Sr Recumbent

Serial Number: E _____

To Activate Warranty:

1. **REGESITOR YOUR WARRANTY AT www.diamondbackfitness.com OR**
2. **COMPLETELY FILL OUT THE ATTACHED WARRANTY CARD (SEE BACK COVER) AND RETURN TO DIAMONDBACK WITHIN 15 DAYS OF THE DATE OF PURCHASE. FAILURE TO COMPLY WITH THE WARRANTY ACTIVATION PROCEDURE MAY VOID THE MANFACTURER'S WARRANTY.**

Serial Number Location



Dealer Name: _____

Dealer Address: _____

Dealer Telephone Number: (____) _____

Dealer Contact Name: _____

Date Purchased: _____

Shipping Materials:
Diamondback recommends that you retain the original packing materials (box and packing items) for future shipping needs.

Table of Contents

Purchaser's Reference Information	2
Introduction	4
Safety Instructions and Warnings	5
900Ub Upright Assembly Drawing	6
900Ub Upright Assembly Instructions	7
900Sr Recumbent Assembly Drawing	9
900Sr Recumbent Assembly Instructions	10
Workout Guidelines	12
Maximum Heart Rate & Training Zone	13
Quantity & Quality	13
Pulse Hand Grips	15
Chest Strap	15
Console	
Glossary of Terms	15
Default Values	16
Operating Tips	16
Console Layout	18
Displays	19
Function Keys	20
Audio	21
Workout Programs	
Warm Up	22
Cool Down	23
Workout Summary	24
Quick Start	24
Classic Programs	
Manual	26
Random	27
Intervals	28
Hill Climb	31
Fitness Test	33
Strength	36
Custom Trainer	37
HR Interactive Programs	
Target HR	40
HR Intervals	42
Maintenance	45
Domestic Warranty Information	46
Warranty Card	51

Introduction

Congratulations on the purchase of your new cardio equipment from Diamondback. You have made a smart choice. You are about to experience one of the most effective and technically advanced methods of cardiovascular exercise available today.

Diamondback Fitness was founded as a brand extension of the legendary 30-year Diamondback bicycle division. The evolution of bicycles to home gyms for cross-training purposes and to stay fit in inclement weather was a natural. Diamondback Fitness, known for delivering feature-packed, high-value equipment, has grown to a full line of cardio equipment including treadmills, ellipticals and stepper, as well as bikes, including innovative step-thru recumbents.

You can count on your Diamondback equipment to provide years of pleasure and improvement in your fitness level. The solid construction and techno-savvy electronics are guaranteed to provide you with the ultimate workout experience.

For more information or questions regarding your equipment, please go to our website at www.diamondbackfitness.com. Or contact us:

Diamondback Fitness
c/o Raleigh America, Inc.
6004 S. 190th Street, Suite 101
Kent, WA 98032
Ph: 800.776.7642

Safety Instructions and Warnings

The 900 model units are built for optimum safety and are designed to meet or exceed all domestic and international standards. However, certain precautions need to be followed when operating any exercise equipment. **BE SURE TO READ THE ENTIRE OWNER'S MANUAL BEFORE OPERATING YOUR 500 MODEL UNIT.**

CAUTION - FOR SAFE OPERATION

1. Before beginning any exercise program on the 900 model unit it is important to consult with your physician if you have any of the following: history of heart disease, high blood pressure, diabetes, chronic respiratory diseases, elevated cholesterol, if you smoke cigarettes, experience any other chronic diseases, or physical complaints.
2. If over the age of 35 or overweight, consult with your physician before beginning any exercise program.
3. Pregnant women should consult with their physician before beginning an exercise program.
4. If you experience dizziness, nausea, chest pains or other abnormal symptoms during exercise, stop the exercise session immediately. consult your physician before continuing your exercise.
5. Drink fluids if you exercise for twenty or more minutes on any 900 model unit.

WARNING - TO REDUCE RISK OF INJURY TO YOURSELF OR OTHERS

1. To ensure proper functioning of your 900 model unit, do not install attachments or accessories not provided or recommended by diamondback.
2. Always wear proper clothing and shoes when exercising on any 900 model unit.
3. User weight is not to exceed 300 pounds / 136 kilograms.
4. Keep children away from 900 model unit. hands and feet may get caught in the pedals or other moving parts which could result in serious injury.
5. Place the 900 model unit in an area that will meet minimum clearance requirements: front, back & sides: 2 feet/60cm
6. Keep 900 model units away from walls to allow proper ventilation. air should be able to circulate freely around the units. keep all air openings free of dirt and dust. never insert anything into openings.
7. The 900 model units are intended for indoor use in home environment. they are not intended for outdoor use.
8. Place your 900 model unit on a solid, level surface when in use.
9. Make sure all knobs for adjustments are fastened securely before getting on the unit and after making an adjustment (i.e. seat post, saddle and handlebars).
10. Use the handlebars getting on and off your 900 model unit.
11. Never operate the unit if it is damaged or broken. contact your local authorized diamondback fitness dealer for service. make sure all components are fastened securely (i.e. seat post, saddle, handlebars and pedals) at all times.

900Ub Upright Assembly Drawing

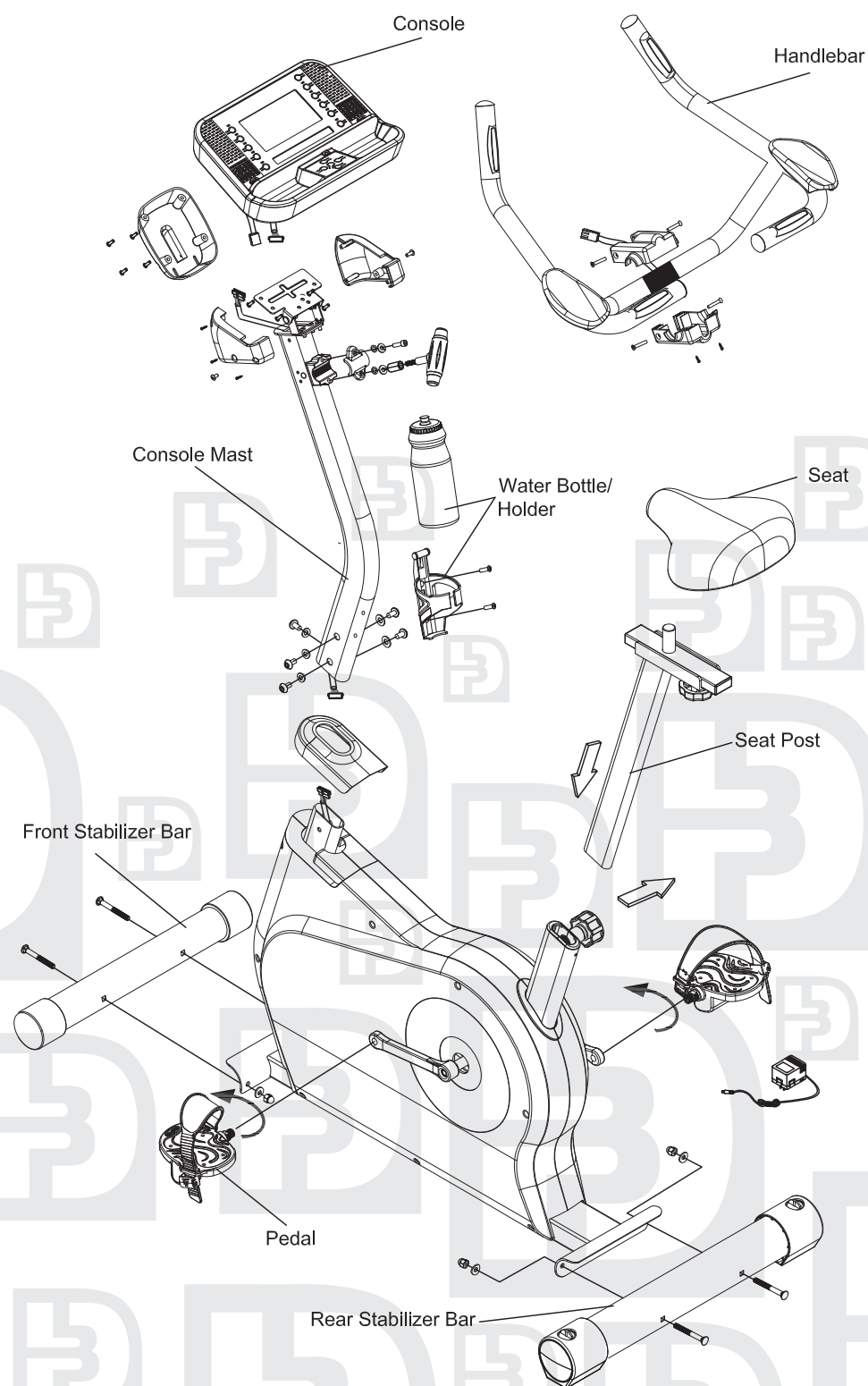

900Ub Upright Assembly Instructions

Step 1: Stabilizer Bars Assembly

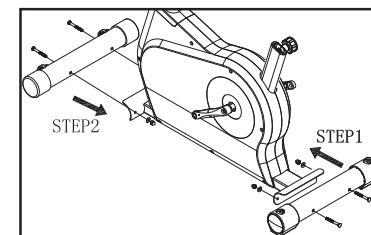

1. Place rear stabilizer bar under rear main frame body and align screw holes.
2. Insert two M8 x 90mm bolts into the stabilizer bar all the way through and into the holes on the frame
3. Secure rear stabilizer bar using an M8 nut and a curved washer on each bolt.
4. Repeat steps 1 - 3 to attach front stabilizer bar.

Step 2: Pedal Assembly

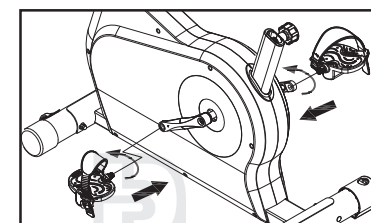

1. Use a 15mm open-end wrench to firmly affix the pedals to the cranks.
2. The left and right pedals are different and are denoted as right or left (R or L) on the top & bottom of each pedal.
NOTE: Left pedal threads counterclockwise.
3. Retighten cranks after approximately 10 hours of use.

Step 3: Seat Post and Saddle assembly

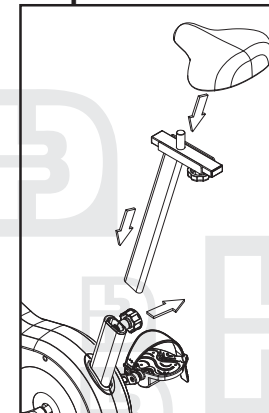

1. Loosen the seat pin by turning it counter-clockwise 1-2 turns. Install seatpost by sliding it into seatpost receptor, pulling the seat pin out until a suitable hole is found.
2. Assemble saddle onto seatpost.
3. Tighten the affixing nut and washer using a 17mm open-end wrench.
SADDLE ANGLE ADJUSTMENT HINT: Hold the rear of saddle in the optimum comfort position and tighten the nut at the same time

Step 4: Console Mast Assembly

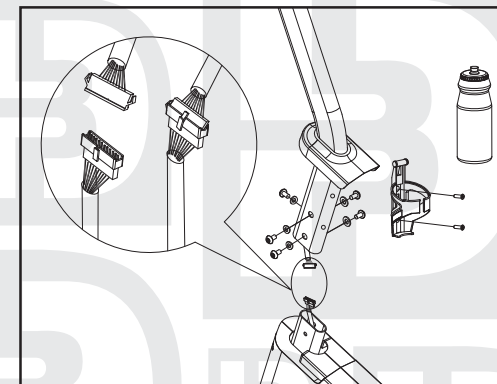

1. Remove the console mast plastic cover from the unit's body by un-snapping it.
2. Install console mast cover onto console mast.
3. Connect the main wire harness in the main frame to the main wire harness in the bottom of the console mast, taking care to install correctly. (See plug alignment marks)
4. Install the console mast by sliding it into the console mast receptor while gently pulling the wiring harness. This will keep the slack out of the harness so the wires will not get pinched and short out. Insert and tighten three M8 x 16mm bolts, one flat washer on each side and a curve washer on the front using a 6mm Allen wrench. Be sure not to pinch wire harness while tightening these three screws and make sure that the two top holes are lined up with the holes on the receptor.

900Ub Upright Assembly Instructions (Continued)

5. Snap console mast cover into top of sidecase.
6. Insert and tighten two M8 x 16mm bolts and flat washers onto the two holes above the console mast cover using a 6mm Allen wrench.
7. Place the bottle holder on the console mast. Insert and tighten the two M5 x 14mm screws using a screwdriver.
8. Snap the water bottle into the bottle holder.

Step 5: Handlebar Assembly

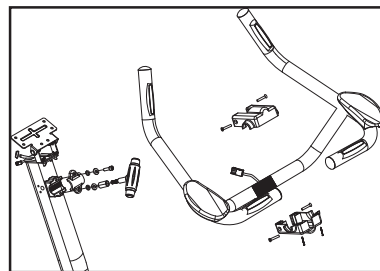

1. Insert the hand pulse harness through the opening on the left side of the console mast and out the top of the console mast.
2. Set the handlebar in place and secure it using a clamp, an M7 x P1.0 x 30mm bolt with a spring washer and flat washer on top hole of the clamp and a T-shape Knob with a bushing, a spring washer and flat washer on bottom hole of the clamp. As the bolt and T-shape knob are tightened leave the same gap on top and bottom.
3. Install the handlebar top and bottom covers by attaching them to each other from the opening in the bottom of the bottom cover using two M3 x 14mm Screws and one M5 x 25mm on each side of each cover.

Step 6: Console Assembly

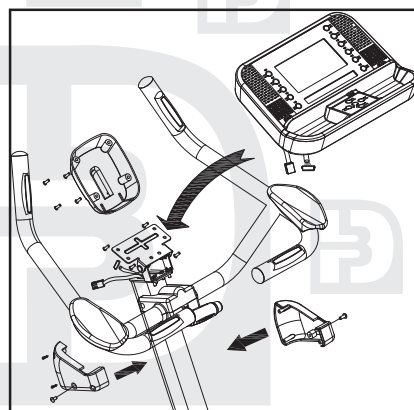

1. Insert the ends of the main wiring harness and hand pulse wiring harness, through the opening of the rear console cover.
2. Connect both plugs, from the main wiring harness and hand pulse wiring harness, to the plug receptors on the backside of the console taking care to install correctly (see plug alignment marks).
WIRING HARNESS INSTALLATION HINT: Any excess wiring must be carefully inserted ("stored") back into the console mast before installing the console onto the console mounting plate.
3. Attach the console to the console mounting plate with the four M5 x 10mm screws on the top and bottom holes of the mounting plate using a Phillips screwdriver.
4. Attach the rear console cover to the back of the console using four M5 x 10mm screws using a Phillips screwdriver.
5. Attach the right Console plastic mount hood to console mast using one M5 x 14mm bolt and Phillips screwdriver. The cover should sit above the plastic handlebar cover and below the mounting bracket for the console.
6. Attach the left console mount cover to console mast using one M5 x 14mm bolt then to the right cover using three M3 x 14mm screws and a Phillips screwdriver.

Step 7: Transformer Assembly

1. Plug transformer into plug receptor located on the rear of the unit
 2. Plug the transformer into power outlet.
- NOTE: Be sure to use the right transformer for your power outlet, 110V or 220V.

900Sr Recumbent Assembly Drawing

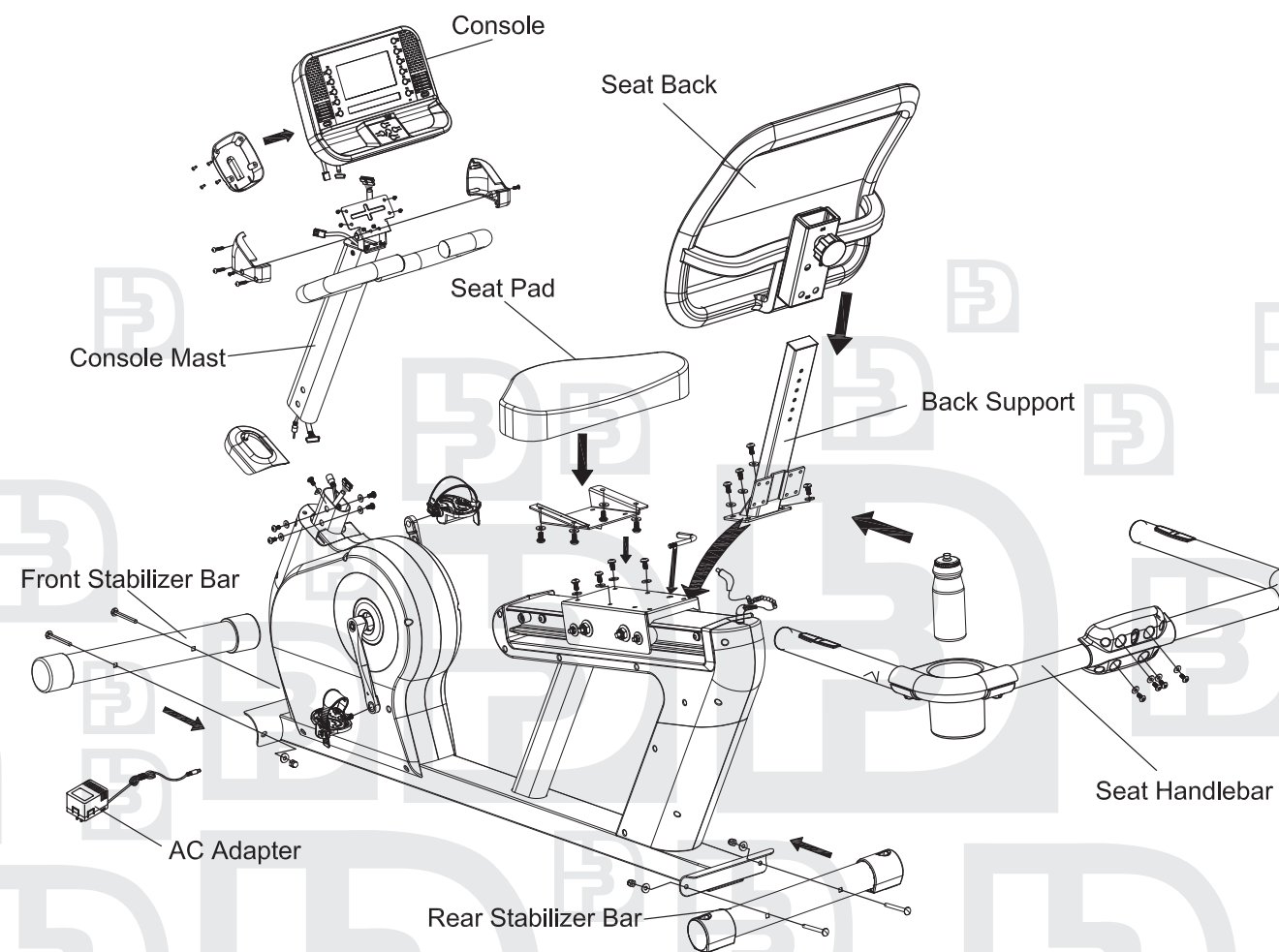

900Sr Recumbent Assembly Instructions

Step 1: Stabilizer Bars Assembly

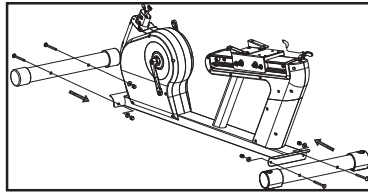

1. Place rear stabilizer bar under rear main frame body and align screw holes.
2. Insert two M8 x 90mm bolts into the stabilizer bar all the way through and into the holes on the frame
3. Secure the stabilizer bar using an M8 nut and a curved washer on each bolt.
4. Repeat steps 1 – 3 to attach front stabilizer.

Step 2: Seat Assembly

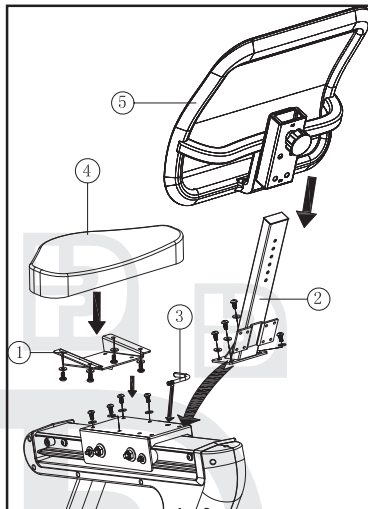

1. Install seat mount bracket to seat slide on the seat track using four M8 x 16mm bolts and four washers.
2. Install seat support to seat slide on the seat track using four M8 x 16mm bolts and four washers.
3. Install the seat locking lever by treading it onto the receiver on the right side of the seat slide. Once treaded in place set it so it is pointing forward and lock it in place using the lock nut.
4. Install the seat pad on seat mount bracket using four M8 x 16mm bolts and four washers
5. Install the seat back locking pin onto the back mount bracket by turning it clockwise. Install the seat back mount bracket by sliding it onto the back support tube, pulling the seat pin out until a suitable hole is found.

Step 3: Rear Handle Bar Assembly

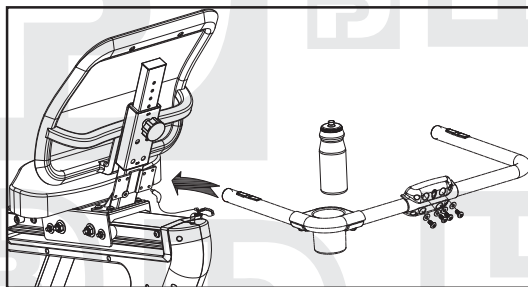

1. Install rear handle bar to the bracket on the rear of the back support tube using four M8 x 16mm and four flat washers
2. Plug in the HR pulse harness coming out of the plastic body to the receptor on the back of the handle bar.

Step 4: Pedals Assembly

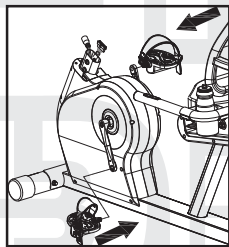

1. Use a 15mm open-end wrench to firmly affix the pedals to the cranks.
2. The left and right pedals are different and are denoted as right or left (R or L) on the top & bottom of each pedal.
NOTE: Left pedal threads counterclockwise.
3. Retighten cranks after approximately 10 hours of use.

900Sr Recumbent Assembly Instructions (Continued)

Step 5: Console Mast Assembly

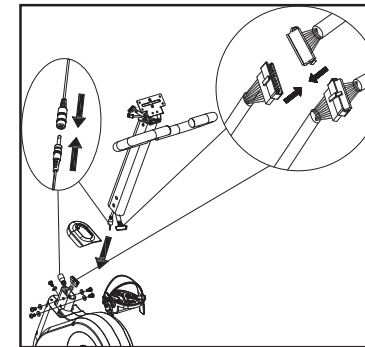

1. Remove console mast plastic cover from the unit's body by un-snapping it.
1. Slide console mast cover onto bottom of console mast
2. Connect both the main wire harness and the hand pulse harness in the main frame to the two wire harnesses in the bottom of the console mast, taking care to install correctly. (See plug alignment marks)
3. Install the console mast by sliding it into the console mast receptor while gently pulling the wiring harnesses. This will keep the slack out of the harness so the wires will not get pinched and short out. Insert and tighten three M8 x 16mm bolts, one flat washer on each side and a curve washer on the front using a 6mm Allen wrench. Be sure not to pinch wire harness while tightening these three screws and make sure that the two top holes are lined up with the holes on the receptor.
4. Snap console mast cover into top of sidecase.
5. Insert and tighten two M8 x 16mm bolts and flat washers onto the two holes above the console mast cover using a 6mm Allen wrench.

Step 6: Console Assembly

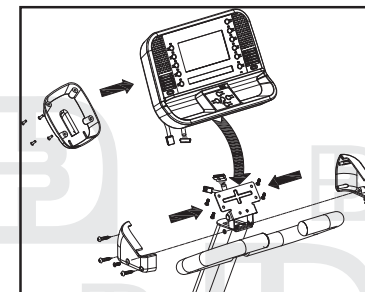

1. Insert the ends of the main wiring harness and hand pulse wiring harness, through the opening of the rear console cover
2. Connect both plugs, from the main wiring harness and hand pulse wiring harness, to the plug receptors on the backside of the console taking care to install correctly (see plug alignment marks).
WIRING HARNESS INSTALLATION HINT: Any excess wiring must be carefully inserted ("stored") back into the console mast before installing the console onto the console mounting plate.
3. Attach the console to the console mounting plate with the four M5 x 10mm screws on the top and bottom holes of the mounting plate using a Phillips screwdriver.
4. Attach the rear console cover to the back of the console using four M5 x 10mm screws using a Phillips screwdriver.
5. Attach the right console plastoc mount hood to console mast using one M5 x 14mm bolt and Phillips screwdriver. The hood should sit above the plastic handlebar cover and below the mounting basket for the console.
6. Attach the left console mount cover to console mast using one M5 x 14mm bolt then to the right cover using three M3 x 14mm screws and a Phillips screwdriver.

Step 7: Transformer Assembly

1. Plug transformer into plug receptor located on the front of the unit.
2. Plug the transformer into power outlet.
NOTE: Be sure to use the right transformer for your power outlet, 110V or 220V.

Workout Guidelines

Good health is an exercise in common sense

The Surgeon General released a study in 2001, The Surgeon General's Call To Action To Prevent and Decrease Overweight and Obesity. It indicates that 61% of American adults are either overweight or obese. The study states that overweight increases the risk of health problems, such as heart disease, certain type of cancer, type 2 diabetes, etc. It further points out that overweight needs to be regarded primarily as a Health rather than as an Appearance issue.

The Surgeon General's Healthy weight advice for consumers is:

1. Aim for a healthy weight: Find your Body Mass Index (BMI) on the chart below.
2. Be active: Keep physically active to balance the calories you consume.
3. Eat well: Select sensible portion sizes.

$$\text{BMI} = (\text{weight (lb)} / \text{height}^2 \text{ (in)}) \times 703$$

Height in Feet and Inches	Weight in Pounds													
	120	130	140	150	160	170	180	190	200	210	220	230	240	250
4'6	29	31	34	36	39	41	43	46	48	51	53	56	58	60
4'8	27	29	31	34	36	38	40	43	45	47	49	52	54	56
4'10	25	27	29	31	34	36	38	40	42	44	46	48	50	52
5'0	23	25	27	29	31	33	35	37	39	41	43	45	47	49
5'2	22	24	26	27	29	31	33	35	37	38	40	42	44	46
5'4	21	22	24	26	28	29	31	33	34	36	38	40	41	43
5'6	19	21	23	24	26	27	29	31	32	34	36	37	39	40
5'8	18	20	21	23	24	26	27	29	30	32	34	35	37	38
5'10	17	19	20	22	23	24	26	27	29	30	32	33	35	36
6'0	16	18	19	20	22	23	24	26	27	28	30	31	33	34
6'2	15	17	18	19	21	22	23	24	26	27	28	30	31	32
6'4	15	16	17	18	20	21	22	23	24	26	27	28	29	30
6'6	14	15	16	17	19	20	21	22	23	24	25	27	28	29
6'8	13	14	15	17	18	19	20	21	22	23	24	25	26	28

Healthy Weight Overweight Obese

Note: This chart is for adults (aged 20 years and older).

Heart rate is an important key to your exercise.

The Surgeon General also released a report on physical activity and health. This report definitively stated that exercise and fitness are beneficial for a person's health and redefined that exercise is a key component of disease prevention and healthier living.

Medical research has shown us that there is an amount of exercise which is enough to condition the cardio respiratory system and the muscles of the body. This amount of exercise is between 60% and 85% of your maximum heart rate measured during a training session. This range allows enough exercise to achieve fitness, but not an excessive amount to cause injury. Your heart rate is an excellent indicator of the amount of stress placed on the cardiovascular system. Taking full advantage of this information, the 900 model units are designed to include heart rate monitoring features.

Workout Guidelines (Continued)

If exercise intensity is too low or too high, no gains will be made in fitness. If the intensity is too low, the stress levels are ineffective. If the intensity is too high, injury or fatigue may set your exercise program back as you try to recover.

The best way to monitor exercise intensity is to accurately count your pulse during exercise. Your heart rate can easily be determined by counting your pulse at the chest, wrist or at the carotid artery on your neck. It is difficult to count your own pulse during exercise, mainly because you cannot count fast enough to get an accurate number. The 900 model units are equipped with a wireless telemetry receiving system. What it does is automatically count your heart rate while you are wearing a heart rate chest belt during your exercising period. Heart rate is monitored and electronically displayed as a digital read-out. Your target heart rate, the intensity needed to improve cardiovascular fitness, depends primarily on your age and not your state of fitness. It is calculated as a percentage of your maximum heart rate, estimated as 220 minus your age. It is most effective to train at your target heart rate between 60% and 85% of your maximum heart rate.

Maximum Heart Rate & Training Zone

To calculate your maximum heart rate and find your training zone, use the following formula. An example has been provided below based on a 35-year-old person:

220 - Age = Maximum Heart Rate (220 - 35 = 185)
 60% of Maximum Heart Rate (60% x 185 = 111bpm)
 85% of Maximum Heart Rate (85% x 185 = 157bpm)
 Training Zone: 111bpm - 157bpm

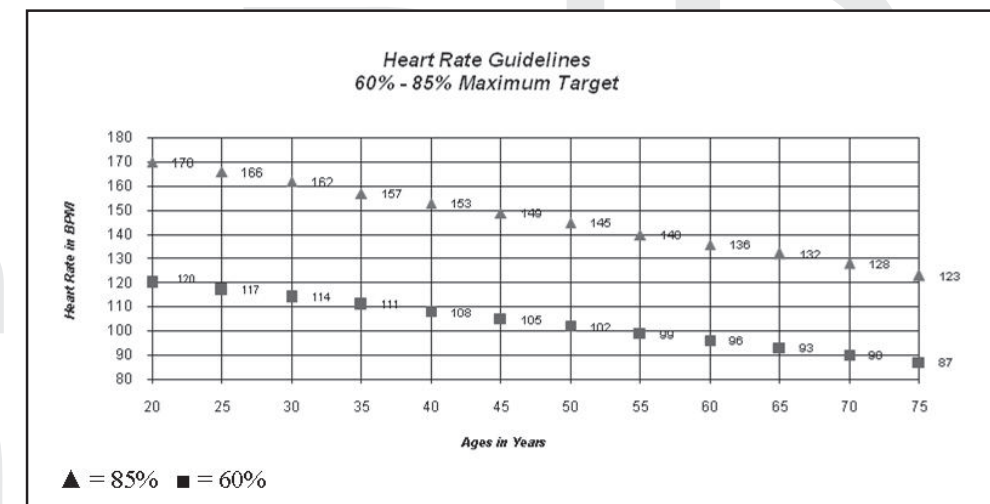

Quantity & Quality

It is recommended that you accumulate at least 30 minutes of physical activity most days of the week. Physical activity should be initiated slowly and the intensity should be increased gradually. You should select activities that you enjoy and can fit into your daily life. Having Diamondback equipment at home certainly gives you the comfortable and convenient workout you want.

The American College of Sports Medicine makes the following recommendations for the quantity and

Workout Guidelines (Continued)

quality of training for developing and maintaining cardio respiratory fitness in healthy adults:

- An activity that uses large muscle groups, maintained continuously, and is rhythmical and aerobic in nature.
- Duration: 20 to 60 minutes of continuous aerobic activity, including a warm-up and cool-down period for each exercise session.
- Frequency: 3 to 5 times per week.
- Intensity: 60% to 85% of maximum heart rate.
- In addition to aerobic exercise, it is recommended that you add strength training of moderate intensity twice per week to your program.

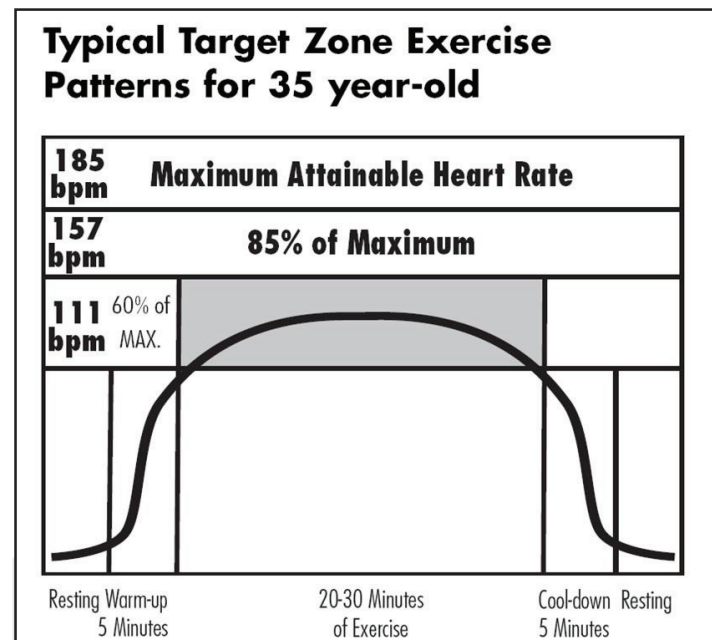

Get a smart start on exercising.

Anyone over the age of 35, as well as younger persons whom are overweight, should check with his/her physician before beginning any type of exercise program. People who have diabetes or high blood pressure, a family history of heart disease, high cholesterol or have lead a sedentary lifestyle should protect themselves with a medical check-up and a stress test, preferably administered during exercise by a healthcare professional.

1. Always stretch before your workout to loosen muscles, and afterwards to Cool Down.
2. The first few minutes of your workout should be devoted to warming up muscles before a vigorous workout, and building your heart rate slowly.
3. After your aerobic workout of about 24-32 minutes, spend 10 minutes gradually reducing your heart rate with a lower resistance level.

Remember, to start slow, with intensity low, until you build endurance and strength. And always consult your physician before beginning any exercise program.

Console

Pulse Hand Grips (Standard)

The 900 Model units are heart rate controlled and come standard with stainless steel pulse handgrips. To activate, gently grasp both handgrips to obtain a heart rate reading. (Note: It is recommended to wear a chest strap for Heart Rate control program, as it is more accurate. If you wear a chest strap and use hand grips at the same time for heart rate monitoring purpose, please note the console will take the measurement of the chest strap.)

Operating Tips:

If you are not getting a consistent reading while using the hand pulse option, we recommend the following suggestions:

- Make sure that the palms of the hands are touching the contact area of each hand pulse grip.
- Maintain an even pressure on the grips.
- Do not hold the hand pulse grips too tightly.

Chest Strap

The 900 Models are equipped with a built-in wireless heart rate receiver for your heart rate monitoring. To get an accurate reading using these devices, you will need to be within three feet of the console, and a minimum of four feet from others using a heart rate monitoring device.

(Note: The transmitter may fluctuate erratically if you are too close to other heart rate monitoring equipment or there is other electronics nearby, such as TV, Radio, cell phone...)

The receiver of the wireless ECG system is built into the console unit of the Diamondback 1300Ef equipments. While using heart rate control modes, the computer monitors the exact measurement of and control over the activity if the heart. Heart rate frequency is displayed while the computer continually compares heart rate to the preprogrammed personal data. The computer adjusts the wattage to maintain heart rate at the preprogrammed level.

How to Wear Your Sensor/ Transmitter

1. Buckle one end of the chest strap onto the transmitter.
2. Adjust the band length so that the fit is snug, but not too tight.
3. Buckle the other end of the chest strap onto the transmitter.
4. Center the transmitter on your chest below the pectoral muscle (breasts).
5. Stretch the transmitter away from your chest and moisten the conductive electrode strips located next to the buckles with water.

(Note: The transmitter is on automatically when being worn. It is off when it is not connected to your body. However, as moisture may activate the transmitter, thoroughly dry the transmitter to prolong battery life.)

Glossary of Terms

- Idle mode = Console is reset and waiting for an entry. The message display window will scroll "DIAMONDBACK FITNESS" and then flash "SELECT A PROGRAM".
- LED = the lights on the face of the console.
- Watts = the rate of energy currently being expended.
- Work = the amount of energy expended during exercise.
- Intensity level = the resistance provided by the unit. The resistance gradually increases as the level goes up.

Console (Continued)

Default Values

- Age = 35 years
- Weight = 155 lb or 70kg for Metric system
- Time = 30 minutes; Segment time = 30/26 minutes.
- Intensity level: Level 1.

Note: The default values for Age, Weight and Time will update each time they are changed in the program settings.

Operating Tips

This console is designed to prompt instructional messages during each phase of a program to guide you through the setup, the executing as well the ending. Follow these instructions, you will find that they are extremely helpful and this console is very simple to use.

- **Power On and Off:** When the AC Adapter is plugged into the unit, it automatically turns on. In the power save mode, press any key or start pedaling to wake up the console and start operation.\
- **Reset:** To reset a program during its operation, press and hold the “Stop” key for 2 seconds. When the program resets, the console returns to idle mode.
- **Pause and Resume:** You may interrupt or pause a program for up to 5 minutes during a workout before the console resets. To pause a program by simply stop pedaling. To resume the program back to the point of where you left off, simply start pedaling.
- **Switching a program:** The user may switch from current operating program to another program by pressing a new program key and then ENTER key to accept the new program. Calories and distance will continue accumulating from previous program.
 - * If any program key is pressed during a program-executing mode, Cool Down mode or workout summary mode it will enter program-switching mode. The message display will flash “Program Name”
 - ◇ If Enter key is pressed, it will enter this program setup mode. The message display will prompt the next setting message for your instruction.
 - ◇ If Start key is pressed, the new program will begin, but Warm Up mode will be skipped.
 - ◇ If 3 seconds passes and no other key is pressed, the program will resume back to previous activities.
 - * Switching a program during a program-executing mode: The new program time will be the time of previous program.
 - * Switching a program during program-ending mode (Cool Down and Workout Summary): The message display will prompt a message for time setting.
 - * Switching a program function could not be active during Quick Start program or Warm Up mode.
- **Re-start a program:** The user may re-start a program after the program ends. Simply press “Start” key during Cool Down or Workout Summary mode. The program will be started immediately without Warm up. The program default will remain the same as previous program; the calories and distance will continue accumulating.
- **Intensity adjustment:** During a program, the user may press Level Up/Down key to adjust the resistance level. (Note: Resistance adjustments are not allowed in any Heart rate interactive program).
 - * If Level Up/Down key is pressed, the message display will show “INTENSITY = 1” to indicate the current level and updates accordingly.

Console (Continued)

- **% MAX HR:** Age / (220 minus age).
It is recommended to control your % Max heart rate within 60% – 85% for the most effective workout. It is also unsafe to exceed 90% and above. This elliptical is equipped with a safety warning message.
 - * If your heart rate reaches 95% of max or goes over, the message display will display “WARNING” & “HR TOO HIGH”. It will also beep twice.
 - * If your heart rate stays at or over 95% of max it will repeat the warning every 3 minutes.
- **English/Metric Unit Setting:** The default Unit setting is the English system. To enter the system switching mode, press and hold the “ENTER” keys for 2 seconds, during Idle mode. The data display will display the message “SELF TEST” press the “UP” or “DOWN” key until the message “UNITS SETUP” comes up and press the “ENTER” key. The message display will display either “ENGLISH” or “METRIC” depending on the setting of the console. Press the “UP” or “DOWN” key to select the preferred units. Press the “ENTER” key to accept the selected units and reset the console to Idle mode.
- **Sound Setting:** By default the Unit will have the sound on. To turn it off, press and hold the “ENTER” keys for 2 seconds, during Idle mode. The data display will display the message “SELF TEST” press the “UP” or “DOWN” key until the message “SOUND SETUP” comes up and press the “ENTER” key. The message display will display either “SOUND ON” or “SOUND OFF” depending on the setting of the console. Press the “UP” or “DOWN” key to turn it off or back on. Press the “ENTER” key to accept the setting and reset the console to Idle mode.

Console Layout

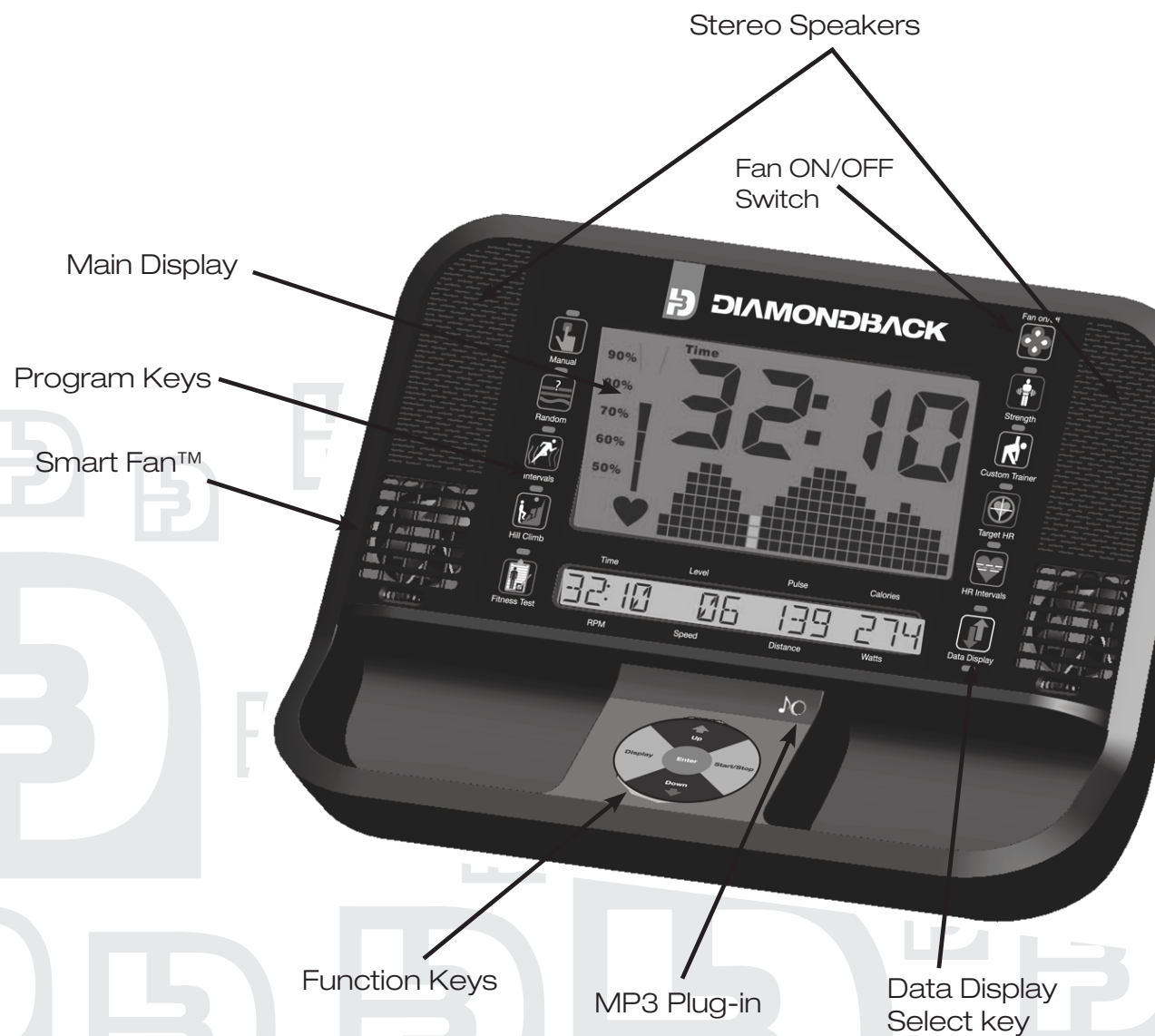

Console Layout (Continued)

Displays

Main Display - The Main Display is divided into three parts, each part is described below:

1. Dot Matrix Display

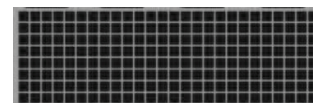

a. It displays the program profile during the program setup and executing modes.

- Displays the Intensity profile during the Classic Program and Custom Training program.
- Displays the % Max HR profile during HR interactive programs

b. Profile definitions:

- Intensity profile - The Dots represent the resistance level, L1- L16; the higher Dots lit up, the higher resistance it is on. The a column of Dots will blink to indicate the current workout segment.
- % Max HR profile - The Dots represents the % Max HR: 0-100%

2. Heart Rate Graph Bar

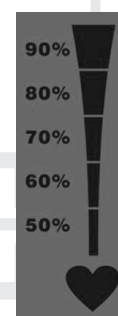

- The heart shape will light up and blink once there is a valid pulse detected.
- It will light up the % Max HR during a program, if there is a valid pulse detected.
- It will use the default age for % calculation unless there is an age entry during setup.

3. Data Display



- During a program it will display Time, Calories, Pulse or Distance.
- It can scan through Time, Calories, Pulse and Distance.
- To indicate what data is being displayed a message right about the data will light up. If the scan function is on, both the data that is being displayed and the Scan message will light up.
- Use the "DISPLAY" key to toggle through the data and to choose the data you prefer to have on the display and to turn on and off the scan function.

Message/Workout data Display



- During a program setup, this display will scroll the messages to guide you through the setup process.
- In the Custom Trainer program, it will display additional messages to take better advantage of your workout.
- During workout, it also acts as data display window and display four types of workout data at the same time. As soon as the program is started it will display Time, Resistance Level, Pulse and Calo-

Function Keys

ries. You may press the “DATA DISPLAY” button to the right of the display to view the RPM, Speed, Distance and Watts. Use the “DATA DISPLAY” button to switch back and forth between the two sets of data that can be displayed.

Function Keys



Level Up/Down Keys

- During program setup, press “Up or Down key” to adjust the following – age, weight, & time
- After program is started, press “Up or Down key” to adjust the intensity level or HR setting.

Enter Key

- After selecting a program, press “Enter” to accept the program and enter its setup mode.
- Adjusting age, weight... press “Enter” key to accept your entry.

Display Key

- Press the “DISPLAY” key to toggle through the data that can be displayed in the main display
- Press the “DIPLAY” until the message “SCAN” lights up in the main display to enable this function. Once the “SCAN” message lights up, press the key again to turn it off and disable this function.

Start/Stop Key

- Press “Start/Stop” to start a program during program setup.
- Press “Start/Stop” to end Warm up and start program immediately.
- Press “Start/Stop” to end a program and start Cool Down.
- Press “Start/Stop” to re-start a program during Cool Down or Workout Summary mode.
- Press and hold “Start/Stop” button to reset the console during program setup mode, warm up mode, Program Execution mode, Workout summary mode.
- Press and hold “Start/Stop” to enter workout summary during Cool Down.

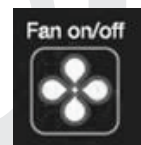

Smart Fan™

The Console features a fan that can be adjusted to direct airflow. Turn the fan on or off by pressing the FAN ON/OFF key.

- Pressing the key once will turn the fan on in smart mode, in this mode the fan will adjust the air flow according to the speed the unit is being pedaled.

Audio

- Pressing the key a second time will turn the fan on to low speed
- Pressing the key a third time will turn the fan on to medium speed
- Pressing the key a fourth time will turn the fan on to high speed
- Pressing the key a fifth time will turn the fan off

Audio

Audio Input Jack & Speakers

The Console features a standard Audio Input Jack and Speakers. Using a two 3.5mm male plug adapter cable connect your audio device to the console. The volume for the speakers is fixed; control the volume of your music using your audio device.

Workout Programs

Warm Up

Getting Started

Your unit will automatically initiate a Warm Up mode for 3 minutes at the beginning of each program. This mode is design to prepare your body for an intensive workout and to reduce the possibility of injury during workout.

Note: Warm Up is skipped for the Quick Start program.

Beginning the Program

Warm Up is active as soon as a START/STOP key is pressed and a program is executed. The message window will flash a message of "WARM UP" and this mode will be started.

During the Program

Main Display

- As soon as the program begins, the Dot Matrix will activate and the 1st segment of the program's profile will start blinking
- If there is a valid Heart rate signal being detected a heart shape will start blinking and the Heart rate graph will light up with the percentage of maximum heart rate.
- The message "Time" will light up in the date display and the Time will start counting down. To switch the data being displayed press the **DISPLAY** key to select from Time, Calories, Pulse and Distance and to turn on and off the scan function.

Message/Data Display

- As soon as the program begins. The message display will turn into workout data display and display four default data: Time, Level, Pulse & Calories and the LED on top of the Data Display key will be lit.
- Press the "DATA DISPLAY" key to switch the display to "RPM, Speed, Distance & Watts". The LED on the bottom of the button will light up.

Adjustment

- Intensity level = L1. Press "**Up or Down**" key to adjust the intensity level from L1- L5 only
- **Start/Stop** key could be pressed to skip the warm up and execute the program immediately.

Ending the Program

- When 3-minutes are up or START/STOP key is pressed, Warm Up will end and the program will execute.
- The message display will flash a message "STARTING PROGRAM" and the selected program will be started.
- The calories and distance will be carried over into the program-executing mode.

Pause, Reset or Switch programs

See Console Operating Tips section for details, page 16

Workout Programs (Continued)

Cool Down

Getting Started

Your unit is equipped with Cool Down at the end of each program. The time for Cool Down is 3 minutes. It appears as soon as a program ends. Cool Down is designed to reduce muscle stiffness and allow your heart rate to recover.

Beginning the Program

Cool Down is active as soon as a program ends or START/STOP key is pressed during program executing. The message window will flash a message of "PROGRAM ENDED" "COOL DOWN" and this mode will be started.

During the Program

Main Display

- As soon as the program will begins, the Dot Matrix will activate and the 1st segment of the program's profile will start blinking
- If there is a valid Heart rate signal being detected a heart shape will start blinking and the Heart rate graph will light up with the percentage of maximum heart rate.
- The message "Time" will light up in the date display and the Time will start counting down. To switch the data being displayed press the **DISPLAY** key to select from Time, Calories, Pulse and Distance and to turn on and off the scan function.

Message/Data Display

- As soon as the program begins. The message display will turn into workout data display and display four default data: Time, Level, Pulse & Calories and the LED on top of the Data Display key will be lit.
- Press the "DATA DISPLAY" key to switch the display to "RPM, Speed, Distance & Watts". The LED on the bottom of the button will light up.

Adjustment

- Intensity level = L1. Press **UP or DOWN** key to adjust the intensity level from L1- L5 only.
- **Start/Stop** key could be pressed to skip the warm up and execute the program immediately.

Ending the Program

- When 3-minutes are up or START/STOP key is pressed and held for 2 seconds, Cool Down will end and enter Workout Summary.
- The message display will flash a message "WORKOUT FINISHED" & "YOUR SUMMARY IS" and the Summary will be displayed.

Pause, Reset or Switch programs

See Console Operating Tips section for details, page 16

Workout Programs (Continued)

Workout Summary

Getting Started

For your convenience, your unit incorporates a Workout Summary right after the completion of the Cool Down. It will display the total workout data for your review and repeat for 1 minute before the Console resets.

Beginning the Program

Workout Summary appears as soon as the Cool Down mode ends or a **START/STOP** key is pressed and held for 2 seconds during Cool Down mode. The message window will flash a message of "WORKOUT FINISHED" & "YOUR SUMMARY IS" and the Summary will be displayed.

During the Program

Display

Once this summary is started, the message window will display each summary for 3 seconds as following:

- TOL TIME as total time.
- TOL DIS as total distance.
- TOL CAL as total calories burned.
- AVG HR as average heart rate over the program period.
- MAX HR as maximum heart rate during this program. (There is no AVG HR or MAX HR displayed if there was no heart rate detected during the program.)
- Press "**Level Down**" key to jump to the next summary display.
- Press "**Level Up**" key to jump to the last total display.

Adjustment

Intensity cannot be adjusted during this time.

Ending the Program

- When 1-minute duration is up or **START/STOP** key is pressed, Workout Summary will end and console will reset.
- The message display will flash a message "RESET CONSOLE". Console will reset and return to idle mode.

Pause, Reset or Switch programs

See Console Operating Tips section for details, page 16

Quick Start

Getting Started

A Quick Start program is for someone who wants to bypass the setup mode and start their workouts right away. By picking Quick Start program, you are accepting the default values for calculations. The

Workout Programs (Continued)

Warm Up mode is skipped at Quick Start program.

Beginning the Program

During idle mode, the message window displays a message "SELECT A PROGRAM". To begin this program, press **START/STOP** key once.

Program Default Values

- Time = 30 minutes
- Intensity level = L1

Note: the default age and weight will be what was entered and saved in a previous workout

During the Program

Main Display

- As soon as the program will begins, the Dot Matrix will activate and the 1st segment of the program's profile will start blinking
- If there is a valid Heart rate signal being detected heart shape will start blinking and the Heart rate graph will light up with the percentage of maximum heart rate.
- The message "Time" will light up in the date display and the Time will start counting down. To switch the data being displayed press the **DISPLAY** key to select from Time, Calories, Pulse and Distance and to turn on and off the scan function.

Message/Data Display

- As soon as the program begins. The message display will turn into workout data display and display four default data: Time, Level, Pulse & Calories and the LED on top of the Data Display key will be lit.
- Press the **DATA DISPLAY** key to switch the display to "RPM, Speed, Distance & Watts". The LED on the bottom of the button will light up.

Adjustment

- Press **UP** or **DOWN** key to adjust the intensity level from L1 to L16. The dot matrix window will update the intensity profile accordingly.

Ending the Program

- When 30-minute duration is up or **START/STOP** key is pressed, this program will end and Workout Summary will be active.
- The message display will flash a message "WORKOUT FINISHED" & "YOUR SUMMARY IS". See Workout Summary for details.
- **START/STOP** key could be pressed to re-start the Quick Start program.
- **START/STOP** key could be pressed and held for 2 seconds to reset the console.

Pause, Reset, or Switch programs

See Console Operating Tips section for details, page 16

Workout Programs (Continued)

Classic Programs

Manual

Getting Started

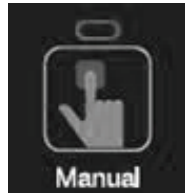

The Manual program has no profile built into it. This allows you to build your own exercise profile while you workout.

Beginning the Program

During idle mode, the message window displays a message "SELECT A PROGRAM". To begin this program, press the **MANUAL** program key, the LED indicator above it will light up.

Entering the program

When the message display flashes, "MANUAL" and "PRESS ENTER", it indicates you are about to select the Manual program. Press **ENTER** Key to enter program setup mode or press the **START/STOP** key to skip the set up mode and use default values.

Press **ENTER** key to enter program set up mode. The message display will take you through the program setup mode step by step as below:

Enter Age

1. The message window will flash a message of "ENTER AGE", then "AGE = XX" with the number blinking.
2. You may press **UP** or **DOWN** keys to adjust the age.
3. After age adjustment, the message display will switch to display "PRESS ENTER" to indicate next step. Press **ENTER** to accept and enter Weight adjustment.

Enter Weight

1. The message window will flash a message of "ENTER WEIGHT", then "WEIGHT = XXX LB" with the number blinking. (WEIGHT = XXX KG" for metric system)
2. You may press **UP** or **DOWN** keys to adjust the weight
3. After weight adjustment, the message display will switch to display "PRESS ENTER" to indicate next step. Press **ENTER** to accept and enter Time adjustment.

Enter your workout time:

1. The message window will flash a message of "ENTER TIME", then "TIME = 30 MIN" and the 30 will be blinking.
2. You may press **UP** or **DOWN** keys to adjust the time. When the time setting reaches 60 minutes, the display will show "TIME = 1HR 00MIN" instead.
3. After time adjustment, the message display will switch to scroll "PRESS ENTER OR START". You may press the **ENTER** or **START/STOP** key to begin this program.

Or press the **START/STOP** key to accept current default values and begin the workout

- Default time = 30 minutes
- Age and weight will be what was enter and saved in a previous workout

Workout Programs (Continued)

During the Program

Once the Enter or Start key is pressed, the Warm Up will be active. See Warm Up mode section for details.

Main Display

- As soon as the program will begins, the Dot Matrix will activate and the 1st segment of the program's profile will start blinking
- If there is a valid Heart rate signal being detected a heart shape will start blinking and the Heart rate graph will light up with the percentage of maximum heart rate.
- The message "Time" will light up in the date display and the Time will start counting down. To switch the data being displayed press the **DISPLAY** key to select from Time, Calories, Pulse and Distance and to turn on and off the scan function.

Message/Data Display

- As soon as the program begins. The message display will turn into workout data display and display four default data: Time, Level, Pulse & Calories and the LED on top of the Data Display key will be lit.
- Press the **DATA DISPLAY** button to switch the display to "RPM, Speed, Distance & Watts". The LED on the bottom of the key will light up.

Adjustment

- Press **UP** or **DOWN** key to adjust the intensity level from L1 to L16. The dot matrix window will update the intensity profile accordingly.

Ending the Program

- When program time is up or **START/STOP** key is pressed, this program will end and Cool Down will be active.
- The message display will flash a message "PROGRAM ENDED"&"COOL DOWN". See Cool Down for details.
- **START/STOP** key could be pressed to re-start the Manual program again.
- **START/STOP** key could be pressed and held for 2 seconds to skip the Cool Down and activate the Workout Summary immediately.

Pause, Reset, Switch or Save a program

See Console Operating Tips section for details, page 16

Random

Getting Started



The Random program is designed to allow the user to choose from an unlimited number of computer generated profiles at random.

Workout Programs (Continued)

Beginning the Program

During idle mode, the message window displays a message “SELECT A PROGRAM”. To begin this program, press the **RANDOM** program key, the LED indicator above it will light up.

Entering the program

When the message display flashes, “RANDOM” and “PRESS ENTER”, it indicates you are about to select the Random program. Press **ENTER** Key to enter program setup mode or press the **START/STOP** key to skip the set up mode and use default values.

Press **ENTER** key to enter program set up mode. The message display will take you through the program setup mode step by step as below:

Enter Age

1. The message window will flash a message of “ENTER AGE”, then “AGE = XX” with the number blinking.
2. You may press **UP** or **DOWN** keys to adjust the age.
3. After age adjustment, the message display will switch to display “PRESS ENTER” to indicate next step. Press **ENTER** to accept and enter Weight adjustment.

Enter Weight

1. The message window will flash a message of “ENTER WEIGHT”, then “WEIGHT = XXX LB” with the number blinking. (WEIGHT = XXX KG” for metric system)
2. You may press **UP** or **DOWN** keys to adjust the weight
3. After weight adjustment, the message display will switch to display “PRESS ENTER” to indicate next step. Press **ENTER** to accept and enter Time adjustment.

Enter your workout time:

1. The message window will flash a message of “ENTER TIME”, then “TIME = 30 MIN” and the 30 will be blinking.
2. You may press **UP** or **DOWN** keys to adjust the time. When the time setting reaches 60 minutes, the display will show “TIME = 1HR 00MIN” instead.
3. After time adjustment, the message display will switch to display “SET UP COMPLETED”, then “PRESS START” to indicate next step. You may press, the **ENTER** or **START/STOP** key to begin this program.

Or press the **START/STOP** key to accept current default values and begin the workout

- Default time = 30 minutes
- Default Intensity level = preset level as shown in dot matrix profile
- Age and weight will be what was enter and saved in a previous workout

During the Program

Once the Enter or Start key is pressed, the Warm Up will be active. See Warm Up mode section for details.

Main Display

- As soon as the program will begins, the Dot Matrix will activate and the 1st segment of the program’s profile will start blinking
- If there is a valid Heart rate signal being detected heart shape will start blinking and the Heart rate

Workout Programs (Continued)

- graph will light up with the percentage of maximum heart rate.
- The message “Time” will light up in the date display and the Time will start counting down. To switch the data being displayed press the **DISPLAY** key to select from Time, Calories, Pulse and Distance and to turn on and off the scan function.

Message/Data Display

- As soon as the program begins. The message display will turn into workout data display and display four default data: Time, Level, Pulse & Calories and the LED on top of the Data Display key will be lit.
- Press the **DATA DISPLAY** buttons to switch the display to “RPM, Speed, Distance & Watts”. The LED on the bottom of the key will light up.

Adjustment

- Press **UP** or **DOWN** key to adjust the intensity level from L1 to L16. The dot matrix window will update the intensity profile accordingly.

Ending the Program

- When program time is up or **START/STOP** key is pressed, this program will end and Cool Down will be active.
- The message display will flash a message “PROGRAM ENDED”&”COOL DOWN”. See Cool Down for details.
- **START/STOP** key could be pressed to re-start the Random program again.
- **START/STOP** key could be pressed and held for 2 seconds to skip the Cool Down and activate the Workout Summary immediately.

Pause, Reset, Switch or Save a program

See Console Operating Tips section for details, page 16

Intervals

Getting Started

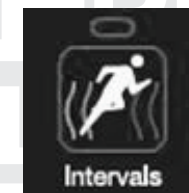

light up.

The Interval Trainer program helps to build the strength of your cardiovascular system. By alternating the workload from high to low, your heart gets an effective workout.

Beginning the Program

During idle mode, the message window displays a message “SELECT A PROGRAM”. To begin this program, press the **INTERVALS** program key, the LED indicator above it will

Entering the program

When the message display flashes, “INTERVALS” and “PRESS ENTER”, it indicates you are about to select the Intervals program. Press **ENTER** Key to enter program setup mode or press the **START/STOP** key to skip the set up mode and use default values.

Press **ENTER** key to enter program set up mode. The message display will take you through the pro-

Workout Programs (Continued)

gram setup mode step by step as below:

Enter Age

1. The message window will flash a message of "ENTER AGE", then "AGE = XX" with the number blinking.
2. You may press UP or **DOWN** keys to adjust the age.
3. After age adjustment, the message display will switch to display "PRESS ENTER" to indicate next step. Press **ENTER** to accept and enter Weight adjustment.

Enter Weight

1. The message window will flash a message of "ENTER WEIGHT", then "WEIGHT = XXX LB" with the number blinking. (WEIGHT = XXX KG" for metric system)
2. You may press **UP** or **DOWN** keys to adjust the weight
3. After weight adjustment, the message display will switch to display "PRESS ENTER" to indicate next step. Press **ENTER** to accept and enter Time adjustment.

Enter your workout time:

1. The message window will flash a message of "ENTER TIME", then "TIME = 30 MIN" and the 30 will be blinking.
2. You may press **UP** or **DOWN** keys to adjust the time. When the time setting reaches 60 minutes, the display will show "TIME = 1HR 00MIN" instead.
3. After time adjustment, the message display will switch to display "SET UP COMPLETED", then "PRESS START" to indicate next step. You may press, the **ENTER** or **START/STOP** key to begin this program.

Or press the **START/STOP** key to accept current default values and begin the workout

- Default time = 30 minutes
- Default Intensity level = preset level as shown in dot matrix profile
- Age and weight will be what was enter and saved in a previous workout

During the Program

Once the Enter or Start key is pressed, the Warm Up will be active. See Warm Up mode section for details.

Main Display

- As soon as the program will begins, the Dot Matrix will activate and the 1st segment of the program's profile will start blinking
- If there is a valid Heart rate signal being detected a heart shape will start blinking and the Heart rate graph will light up with the percentage of maximum heart rate.
- The message "Time" will light up in the date display and the Time will start counting down. To switch the data being displayed press the **DISPLAY** key to select from Time, Calories, Pulse and Distance and to turn on and off the scan function.

Message/Data Display

- As soon as the program begins. The message display will turn into workout data display and display four default data: Time, Level, Pulse & Calories and the LED on top of the Data Display key will be lit.
- Press the "DATA DISPLAY" buttons to switch the display to "RPM, Speed, Distance & Watts". The LED on the bottom of the key will light up.

Workout Programs (Continued)

Adjustment

- Press **UP** or **DOWN** key to adjust the intensity level from L1 to L16. The dot matrix window will update the intensity profile accordingly.

Ending the Program

- When program time is up or **START/STOP** key is pressed, this program will end and Cool Down will be active.
- The message display will flash a message "PROGRAM ENDED"&"COOL DOWN". See Cool Down for details.
- **START/STOP** key could be pressed to re-start the Intervals program again.
- **START/STOP** key could be pressed and held for 2 seconds to skip the Cool Down and activate the Workout Summary immediately.

Pause, Reset, Switch or Save a program

See Console Operating Tips section for details, page 16

Hill Climb

Getting Started

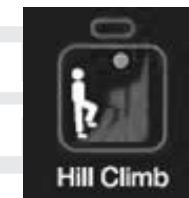

The Hill program simulates a hill climbing exercise with a preset hill profile. The exercise profile will guide you up over a hill and down the other side.

Beginning the Program

During idle mode, the message window displays a message "SELECT A PROGRAM". To begin this program, press the **HILL CLIMB** program key, the LED indicator above it will light up.

Entering the program

When the message display flashes, "HILL CLIMB" and "PRESS ENTER", it indicates you are about to select the Hill Climb program. Press **ENTER** Key to enter program setup mode or press the **START/STOP** key to skip the set up mode and use default values.

Press **ENTER** key to enter program set up mode. The message display will take you through the program setup mode step by step as below:

Enter Age

1. The message window will flash a message of "ENTER AGE", then "AGE = XX" with the number blinking.
2. You may press **UP** or **DOWN** keys to adjust the age.
3. After age adjustment, the message display will switch to display "PRESS ENTER" to indicate next step. Press **ENTER** to accept and enter Weight adjustment.

Enter Weight

1. The message window will flash a message of "ENTER WEIGHT", then "WEIGHT = XXX LB" with the number blinking. (WEIGHT = XXX KG" for metric system)

Workout Programs (Continued)

- You may press **UP** or **DOWN** keys to adjust the weight
- After weight adjustment, the message display will switch to display "PRESS ENTER" to indicate next step. Press **ENTER** to accept and enter Time adjustment.

Enter your workout time:

- The message window will flash a message of "ENTER TIME", then "TIME = 30 MIN" and the 30 will be blinking.
- You may press **UP** or **DOWN** keys to adjust the time. When the time setting reaches 60 minutes, the display will show "TIME = 1HR 00MIN" instead.
- After time adjustment, the message display will switch to display "SET UP COMPLETED", then "PRESS START" to indicate next step. You may press, the **ENTER** or **START/STOP** key to begin this program.

Or press the **START/STOP** key to accept current default values and begin the workout

- Default time = 30 minutes
- Default Intensity level = preset level as shown in dot matrix profile
- Age and weight will be what was enter and saved in a previous workout

During the Program

Once the Enter or Start key is pressed, the Warm Up will be active. See Warm Up mode section for details.

Main Display

- As soon as the program will begins, the Dot Matrix will activate and the 1st segment of the program's profile will start blinking
- If there is a valid Heart rate signal being detected a heart shape will start blinking and the Heart rate graph will light up with the percentage of maximum heart rate.
- The message "Time" will light up in the date display and the Time will start counting down. To switch the data being displayed press the **DISPLAY** key to select from Time, Calories, Pulse and Distance and to turn on and off the scan function.

Message/Data Display

- As soon as the program begins. The message display will turn into workout data display and display four default data: Time, Level, Pulse & Calories and the LED on top of the Data Display key will be lit.
- Press the **DATA DISPLAY** buttons to switch the display to "RPM, Speed, Distance & Watts". The LED on the bottom of the key will light up.

Adjustment

- Press **UP** or **DOWN** key to adjust the intensity level from L1 to L16. The dot matrix window will update the intensity profile accordingly.

Ending the Program

- When program time is up or **START/STOP** key is pressed, this program will end and Cool Down will be active.
- The message display will flash a message "PROGRAM ENDED"&"COOL DOWN". See Cool Down for details.
- START/STOP** key could be pressed to re-start the Hill Climb program again.

Workout Programs (Continued)

- START/STOP** key could be pressed and held for 2 seconds to skip the Cool Down and activate the Workout Summary immediately.

Pause, Reset, Switch or Save a program

See Console Operating Tips section for details, page 16

Fitness Test

Getting Started



Fitness Test

The Fitness Test is based on YMCA protocol Standards, is provided as a tool to evaluate your fitness level. During exercise, the muscles covert oxygen to the fuel needed for the muscles to do the required work. The harder you work the more oxygen the muscles require. This oxygen, or fuel, is delivered to the muscles by the cardiovascular, or blood, system. The harder you exercise the faster your heart beats in order to maintain the fuel supply to the muscles. As your fitness level improves, your muscles become more efficient and therefore do not require as much fuel. This means your heart does not have to beat as fast as before to do the same amount of work.

The Fitness Test uses this basic knowledge to determine how fit you are. During the test, the user is introduced to predetermined workloads. The reaction of your heart is then monitored to these workloads. At the end of the test you will be provided with a score based on the results. This score will give you a starting point to use in tracking your fitness progress. Use this test occasionally to monitor the improvement in your level of fitness. Be sure to include a warm-up or cool-down period in your exercise session.

A HEART RATE MONITORING DEVICE MUST BE USED FOR THIS PROGRAM.

Beginning the Program

During idle mode, the message window displays a message "SELECT A PROGRAM". To begin this program, press the **FITNESS TEST** program key, the LED indicator above it will light up.

Entering the program

When the message display flashes, "FITNESS TEST" and "PRESS ENTER", it indicates you are about to select the Fitness Test program. Press **ENTER** Key to enter program setup mode or press the **START/STOP** key to skip the set up mode and use default values.

Press ENTER key to enter program set up mode. The message display will take you through the program setup mode step by step as below:

Enter Age

- The message window will flash a message of "ENTER AGE", then "AGE = XX" with the number blinking.
- You may press **UP** or **DOWN** keys to adjust the age.
- After age adjustment, the message display will switch to display "PRESS ENTER" to indicate next step. Press **ENTER** to accept and enter Weight adjustment.

Enter Weight

- The message window will flash a message of "ENTER WEIGHT", then "WEIGHT = XXX LB"

Workout Programs (Continued)

- with the number blinking. (WEIGHT = XXX KG" for metric system)
- You may press **UP** or **DOWN** keys to adjust the weight
 - After weight adjustment, the message display will switch to display "PRESS ENTER" to indicate next step. Press **ENTER** to accept and enter the program

Or press the **START/STOP** key to accept current default values and begin the workout

- Default time = will be determined by your Heart rate
- Default Intensity level = will be determined by your Heart rate
- Age and weight will be what was enter and saved in a previous workout

During the Program

Once the Enter or Start key is pressed, the program will start and Warm Up will be skipped. During this program you MUST maintain the RPMs at 50.

Main Display

- As soon as the program will begins, the Dot Matrix will activate, four segments will light up and the 1st segment will start blinking
- If there is a valid Heart rate signal being detected a heart shape will start blinking and the Heart rate graph will light up with the percentage of maximum heart rate.
- The message "Time" will light up in the date display and the Time will start counting up. To switch the data being displayed press the **DISPLAY** key to select from Time, Calories, Pulse and Distance and to turn on and off the scan function.

Message/Data Display

- There is more than one stage in this program, as soon as the program begins the message display will show the message of "STAGE 1", as the test progresses and a new stage is started the message display will indicate that by displaying the stage number it about to start.
- The console will detect if there is a valid pulse. If there is none, this program will be stopped. The messages display will scroll "NO HR DETECTED CHECK YOUR PULSE SENSOR" until there is valid pulse.
- After a message is displayed, the message display will show workout data and display four sets of default data: Time, Level, Pulse & Calories and the LED on top of the Data Display key will be lit.
- Press the **DATA DISPLAY** buttons to switch the display to "RPM, Speed, Distance & Watts". The LED on the bottom of the key will light up.

Adjustment

- Press **UP** or **DOWN** key will do nothing there are no adjust intensity level adjustments during this program. The console will control the resistance.

Ending the Program

- Program will end when in two stages the HR readings are higher than 110BPM.
- The message display will display "MAX METS = X.X"
- START/STOP** key is pressed, this program will end and Cool Down will be active, but the test will not be completed and depending on how far along the test you were no Max METs will be displayed.
- HR reached 85% of Max. and the test was stopped; depending on how far along the test you were Max METs may not be displayed.
- The message display will display "MAX METS = X.X" or if the test was unsuccessfully completed the

Workout Programs (Continued)

- message display will scroll "UNABLE TO COMPLETE TEST"
- The message display will then flash a message "PROGRAM ENDED"&"COOL DOWN". See Cool Down for details.
 - START/STOP** key could be pressed and held for 2 seconds to skip the Cool Down and activate the Workout Summary immediately.

The "MAX METS" measurement given at the end of the Fitness Test is a value that represents your functional capacity for aerobic exercise. It is expressed in METS, or metabolic units. This value factors in your body weight, but not your age or whether you are male or female.

The ACSM (American College of Sports Medicine) gives some guidelines about aerobic fitness and METS capacity¹:

Functional Capacity (METS)	Fitness Level*
1.0 – 3.9	Poor
4.0 – 6.9	Low
7.0 – 10.9	Average
11.0 – 13.9	Good
14.0 – 16.0	High

*for 40- year old males

Note that the information given is for a 40-year old male. Depending on your age and sex, these values can differ.

Knowing your functional capacity can also tell you how difficult it may be to perform certain activities. For example, cycling (for pleasure or to work) generally requires about 3-8 METS, fast cycling at 10MPH requires about 7 METS¹. So, if your functional capacity is 6 METS it would be difficult for you to ride a cycle at 10MPH for any extended length of time.

For more information about METS capacity or if you have concerns about your fitness level, consult ACSM guidelines or a personal trainer.

¹taken from the "ACSM Guidelines for Exercise Testing and Prescription", 4th Edition.

Pause, Reset, Switch or Save a program

See Console Operating Tips section for details, page 16

Workout Programs (Continued)

Strength

Getting Started



The Strength program increases the workload as the workout progresses. This program is focused on strengthening your heart and your major muscle groups.

Beginning the Program

During idle mode, the message window displays a message "SELECT A PROGRAM". To begin this program, press the **STRENGTH** program key, the LED indicator above it will light up.

Entering the program

When the message display flashes, "STRENGTH" and "PRESS ENTER", it indicates you are about to select the Strength program. Press **ENTER** Key to enter program setup mode or press the **START/STOP** key to skip the set up mode and use default values.

Press **ENTER** key to enter program set up mode. The message display will take you through the program setup mode step by step as below:

Enter Age

1. The message window will flash a message of "ENTER AGE", then "AGE = XX" with the number blinking.
2. You may press **UP** or **DOWN** keys to adjust the age.
3. After age adjustment, the message display will switch to display "PRESS ENTER" to indicate next step. Press **ENTER** to accept and enter Weight adjustment.

Enter Weight

1. The message window will flash a message of "ENTER WEIGHT", then "WEIGHT = XXX LB" with the number blinking. (WEIGHT = XXX KG" for metric system)
2. You may press **UP** or **DOWN** keys to adjust the weight
3. After weight adjustment, the message display will switch to display "PRESS ENTER" to indicate next step. Press **ENTER** to accept and enter Time adjustment.

Enter your workout time:

1. The message window will flash a message of "ENTER TIME", then "TIME = 30 MIN" and the 30 will be blinking.
2. You may press **UP** or **DOWN** keys to adjust the time. When the time setting reaches 60 minutes, the display will show "TIME = 1HR 00MIN" instead.
3. After time adjustment, the message display will switch to display "SET UP COMPLETED", then "PRESS START" to indicate next step. You may press, the **ENTER** or **START/STOP** key to begin this program.

Or press the **START/STOP** key to accept current default values and begin the workout

- Default time = 30 minutes
- Default Intensity level = preset level as shown in dot matrix profile
- Age and weight will be what was enter and saved in a previous workout

Workout Programs (Continued)

During the Program

Once the Enter or Start key is pressed, the Warm Up will be active. See Warm Up mode section for details.

Main Display

- As soon as the program will begins, the Dot Matrix will activate and the 1st segment of the program's profile will start blinking
- If there is a valid Heart rate signal being detected a heart shape will start blinking and the Heart rate graph will light up with the percentage of maximum heart rate.
- The message "Time" will light up in the date display and the Time will start counting down. To switch the data being displayed press the **DISPLAY** key to select from Time, Calories, Pulse and Distance and to turn on and off the scan function.

Message/Data Display

- As soon as the program begins. The message display will turn into workout data display and display four default data: Time, Level, Pulse & Calories and the LED on top of the Data Display key will be lit.
- Press the **DATA DISPLAY** buttons to switch the display to "RPM, Speed, Distance & Watts". The LED on the bottom of the key will light up.

Adjustment

- Press **UP** or **DOWN** key to adjust the intensity level from L1 to L16. The dot matrix window will update the intensity profile accordingly.

Ending the Program

- When program time is up or **START/STOP** key is pressed, this program will end and Cool Down will be active.
- The message display will flash a message "PROGRAM ENDED"&"COOL DOWN". See Cool Down for details.
- **START/STOP** key could be pressed to re-start the Strength program again.
- **START/STOP** key could be pressed and held for 2 seconds to skip the Cool Down and activate the Workout Summary immediately.

Pause, Reset, Switch or Save a program

See Console Operating Tips section for details, page 16

Custom Trainer

Getting Started

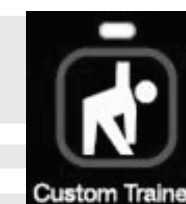

This program is designed to allow you to customize your workout. It includes a preset intensity profile that can be modified as needed, before the program is started, during the workout or both. The changes to each segment will be saved for future use.

Workout Programs (Continued)

Beginning the Program

During idle mode, the message window displays a message “SELECT A PROGRAM”. To begin this program, press the **CUSTOM TRAINER** program key, the LED indicator above it will light up.

Entering the program

When the message display flashes, “CUSTOM TRAINER” and “PRESS ENTER”, it indicates you are about to select the Custom Trainer program. Press **ENTER** Key to enter program setup mode or press the **START/STOP** key to skip the set up mode and use default values.

Press **ENTER** key to enter program set up mode. The message display will take you through the program setup mode step by step as below:

Enter Age

1. The message window will flash a message of “ENTER AGE”, then “AGE = XX” with the number blinking.
2. You may press **UP** or **DOWN** keys to adjust the age.
3. After age adjustment, the message display will switch to display “PRESS ENTER” to indicate next step. Press **ENTER** to accept and enter Weight adjustment.

Enter Weight

1. The message window will flash a message of “ENTER WEIGHT”, then “WEIGHT = XXX LB” with the number blinking. (WEIGHT = XXX KG” for metric system)
2. You may press **UP** or **DOWN** keys to adjust the weight
3. After weight adjustment, the message display will switch to display “PRESS ENTER” to indicate next step. Press **ENTER** to accept and enter Time adjustment.

Enter your workout time:

1. The message window will flash a message of “ENTER TIME”, then “TIME = 30 MIN” and the 30 will be blinking.
2. You may press **UP** or **DOWN** keys to adjust the time. When the time setting reaches 60 minutes, the display will show “TIME = 1HR 00MIN” instead.
3. After weight adjustment, the message display will switch to display “PRESS ENTER” to indicate next step. Press **ENTER** to accept and enter the profile modification mode.

Modify Profile:

1. The message window will display a message of “MODIFY PROFILE”.
2. You may press **UP** or **DOWN** key to modify the profile from level 1 to level 16. The Dot matrix will adjust accordingly.
3. After each segment is adjusted to the preferred resistance level press **ENTER** key to move to the next segment.
4. The message “PRESS ENTER OR START” will be displayed during the modification of the profile indicating that you can press the **ENTER** key to continue modifying the Profile or the **START/STOP** key to skip the modification process and go in to the program.

Or press the **START/STOP** key to accept current default values and begin the workout

- Default time = 30 minutes
- Default Intensity = preset level as shown in dot matrix profile
- Age and weight will be what was enter and saved in a previous workout

Workout Programs (Continued)

During the Program

Once the Enter or Start key is pressed, the Warm Up will be active. See Warm Up mode section for details.

Main Display

- As soon as the program will begins, the Dot Matrix will activate and the 1st segment of the program’s profile will start blinking
- If there is a valid Heart rate signal being detected a heart shape will start blinking and the Heart rate graph will light up with the percentage of maximum heart rate.
- The message “Time” will light up in the date display and the Time will start counting down. To switch the data being displayed press the **DISPLAY** key to select from Time, Calories, Pulse and Distance and to turn on and off the scan function.

Message/Data Display

- As soon as the program begins. The message display will turn into workout data display and display four default data: Time, Level, Pulse & Calories and the LED on top of the Data Display key will be lit.
- Press the **DATA DISPLAY** buttons to switch the display to “RPM, Speed, Distance & Watts”. The LED on the bottom of the key will light up.

Adjustment

- Press **UP** or **DOWN** key to adjust the intensity level from L1 to L16. The dot matrix window will update the intensity profile accordingly and save the change if you press the **ENTER** key.

Ending the Program

- When program time is up or **START/STOP** key is pressed, this program will end and Cool Down will be active.
- The message display will flash a message “PROGRAM ENDED”&”COOL DOWN”. See Cool Down for details.
- **START/STOP** key could be pressed to re-start the Strength program again.
- **START/STOP** key could be pressed and held for 2 seconds to skip the Cool Down and activate the Workout Summary immediately.

Pause, Reset, Switch or Save a program

See Console Operating Tips section for details, page 16

Workout Programs (Continued)

HR Interactive Programs

Dot matrix display during HR Interactive programs – The dot matrix display will display the % Max HR profile, not intensity profile. The row of target % Max HR LEDs will light up to indicate your goal; then the current segment LEDs will light up and blink to show your actual heart rate. You could compare your actual heart rate against your goal while exercising.

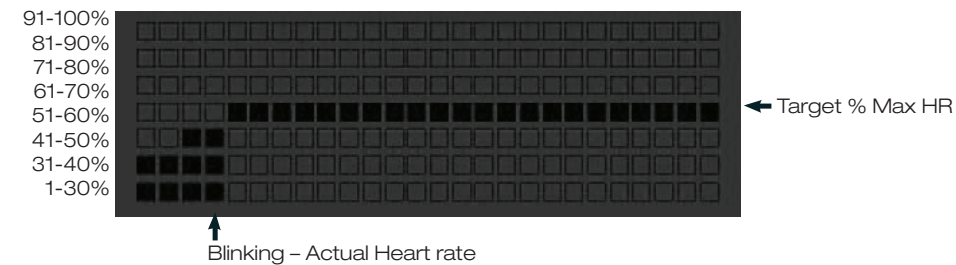

Target HR

Getting Started

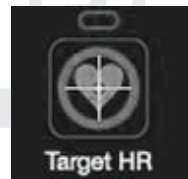

The Target Heart Rate program is designed to keep you training at your chosen heart rate level. Computer will adjust the intensity level automatically to ensure the target heart rate is achieved and maintained during the entire program.

A CHEST STRAP OR HAND SENSORS MUST BE USED FOR THIS PROGRAM.

IMPORTANT: It is unsafe to exceed 95% of your maximum heart rate while exercising.

Please consult your physician before performing any Heart Rate based training program.

Beginning the Program

During idle mode, the message window displays a message “SELECT A PROGRAM”. To begin this program, press the **TARGET HR** program key, the LED indicator above it will light up.

Entering the program

When the message display flashes, “TARGET HR” and “PRESS ENTER”, it indicates you are about to select the Target HR program. Press **ENTER** Key to enter program setup mode or press the **START/STOP** key to skip the set up mode and use default values.

Press **ENTER** key to enter program set up mode. The message display will take you through the program setup mode step by step as below:

Enter Age

1. The message window will flash a message of “ENTER AGE”, then “AGE = XX” with the number blinking.
2. You may press **UP** or **DOWN** keys to adjust the age.
3. After age adjustment, the message display will switch to display “PRESS ENTER” to indicate next step. Press **ENTER** to accept and enter Weight adjustment.

Enter Weight

1. The message window will flash a message of “ENTER WEIGHT”, then “WEIGHT = XXX LB” with the number blinking. (WEIGHT = XXX KG” for metric system)
2. You may press **UP** or **DOWN** keys to adjust the weight
3. After weight adjustment, the message display will switch to display “PRESS ENTER” to indicate next step. Press **ENTER** to accept and enter Time adjustment.

Enter your workout time:

1. The message window will flash a message of “ENTER TIME”, then “TIME = 30 MIN” and the 30 will be blinking.
2. You may press **UP** or **DOWN** keys to adjust the time. When the time setting reaches 60 minutes, the display will show “TIME = 1HR 00MIN” instead.
3. After time adjustment, the message display will switch to display “SET UP COMPLETED”, then “PRESS START” to indicate next step. You may press, the **ENTER** or **START/STOP** key to begin this program.

Or press the **START/STOP** key to accept current default values and begin the workout

- Default time = 30 minutes
- Age and weight will be what was enter and saved in a previous workout

During the Program

Once Start key is pressed, the Warm Up will be active. See Warm Up mode section for details.

Message/Data Display

- When warm up mode is completed, the console will detect if there is a valid pulse before starting this program. If there is none, this program will not be started. The messages display will scroll “NO HR DETECTED CHECK YOUR PULSE SENSOR” until there is valid pulse.
- Once there is a valid pulse, this program will be active. The message display will turn into workout data display and display four default data: Time, Level, Pulse & Calories and the LED on top of the Data Display key will be lit.
- Press the **DATA DISPLAY** buttons to switch the display to “RPM, Speed, Distance & Watts”. The LED on the bottom of the key will light up.

Main Display

- The Dot Matrix will activate and the 1st segment of the program’s profile will start blinking
- If there is a valid Heart rate signal being detected a heart shape will start blinking and the Heart rate graph will light up with the percentage of maximum heart rate.
- The message “Time” will light up in the date display and the Time will start counting down. To switch the data being displayed press the **DISPLAY** key to select from Time, Calories, Pulse and Distance and to turn on and off the scan function.

Adjustment

- Press **UP** or **DOWN** key to adjust the desired Target HR. The dot matrix window will update the % Max HR profile accordingly. The pulse display will switch from displaying the actual HR to show the current target HR and adjust as the key is being pressed. Minimum adjust value is 65% of Max HR. Maximum adjust value is 85% of Max HR

Workout Programs (Continued)

Ending the Program

- When program time is up or **START/STOP** key is pressed, this program will end and Cool Down will be active.
- The message display will flash a message "PROGRAM ENDED"&"COOL DOWN". See Cool Down for details.
- **START/STOP** key could be pressed to re-start the Target HR program again.
- **START/STOP** key could be pressed and held for 2 seconds to skip the Cool Down and activate the Workout Summary immediately.

Pause, Reset, Switch or Save a program

See Console Operating Tips section for details, page 16

HR Intervals

Getting Started

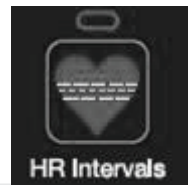

The Heart Rate Interval program is designed to alternate periods of hard work (Work phase) with periods of easy work (Rest phase). The console will adjust the resistance level up to meet your Work heart rate goal and adjust it down to recover.

A HEART RATE MONITORING DEVICE MUST BE USED FOR THIS PROGRAM.

IMPORTANT: It is unsafe to exceed 95% of your maximum heart rate while exercising. Please consult your physician before performing any Heart Rate based training program.

Beginning the Program

During idle mode, the message window displays a message "SELECT A PROGRAM". To begin this program, press the **HR INTERVALS** program key, the LED indicator above it will light up.

Entering the program

When the message display flashes, "HR INTERVALS" and "PRESS ENTER", it indicates you are about to select the HR intervals program. Press **ENTER** Key to enter program setup mode or press the **START/STOP** key to skip the set up mode and use default values.

Press **ENTER** key to enter program set up mode. The message display will take you through the program setup mode step by step as below:

Enter Age

1. The message window will flash a message of "ENTER AGE", then "AGE = XX" with the number blinking.
2. You may press **UP** or **DOWN** keys to adjust the age.
3. After age adjustment, the message display will switch to display "PRESS ENTER" to indicate next step. Press **ENTER** to accept and enter Weight adjustment.

Enter Weight

1. The message window will flash a message of "ENTER WEIGHT", then "WEIGHT = XXX LB" with the number blinking. (WEIGHT = XXX KG" for metric system)

Workout Programs (Continued)

2. You may press **UP** or **DOWN** keys to adjust the weight
3. After weight adjustment, the message display will switch to display "PRESS ENTER" to indicate next step. Press **ENTER** to accept and enter Time adjustment.

Enter your workout time:

1. The message window will flash a message of "ENTER TIME", then "TIME = 30 MIN" and the 30 will be blinking.
2. You may press **UP** or **DOWN** keys to adjust the time. When the time setting reaches 60 minutes, the display will show "TIME = 1HR 00MIN" instead.
3. After time adjustment, the message display will switch to display "SET UP COMPLETED", then "PRESS START" to indicate next step. You may press, the **ENTER** or **START/STOP** key to begin this program.

Or press the **START/STOP** key to accept current default values and begin the workout

- Default time = 30 minutes
- Age and weight will be what was enter and saved in a previous workout

During the Program

Once Start key is pressed, the Warm Up will be active. See Warm Up mode section for details.

Message/Data Display

- When warm up mode is completed, the console will detect if there is a valid pulse before starting this program. If there is none, this program will not be started. The messages display will scroll "NO HR DETECTED CHECK YOUR PULSE SENSOR" until there is valid pulse.
- Once there is a valid pulse, this program will be active. The message display will turn into workout data display and display four default data: Time, Level, Pulse & Calories and the LED on top of the Data Display key will be lit.
- Press the **DATA DISPLAY** buttons to switch the display to "RPM, Speed, Distance & Watts". The LED on the bottom of the key will light up.

Main Display

- The Dot Matrix will activate and the 1st segment of the program's profile will start blinking
- If there is a valid Heart rate signal being detected a heart shape will start blinking and the Heart rate graph will light up with the percentage of maximum heart rate.
- The message "Time" will light up in the date display and the Time will start counting down. To switch the data being displayed press the **DISPLAY** key to select from Time, Calories, Pulse and Distance and to turn on and off the scan function.

Adjustment

- Press **UP** or **DOWN** key during Rest HR segment to adjust the Rest HR setting of the remaining program. The message display will display "REST HR = XXXPCENT" and adjust accordingly. The dot matrix window will update the % Max HR of Rest phase profile accordingly. Minimum value for Rest HR adjustment is 60% max HR. Max value for Rest Setting adjustment is the current Work HR.
- Press **UP** or **DOWN** key during Work HR segment to adjust the Work HR setting of the remaining program. The message display will display "WORK HR = XXXPCENT" and adjust accordingly. The dot matrix window will update the % Max HR of Work phase profile accordingly. Minimum value for Work HR adjustment is the current Rest HR. Max value for Work HR adjust is 90% of Max HR.
- After an adjustment, press **ENTER** key to confirm.

Workout Programs (Continued)

Ending the Program

- When program time is up or **START/STOP** key is pressed, this program will end and Cool Down will be active.
- The message display will flash a message “PROGRAM ENDED” & “COOL DOWN”. See Cool Down for details.
- **START/STOP** key could be pressed to re-start the HR Intervals program again.
- **START/STOP** key could be pressed and held for 2 seconds to skip the Cool Down and activate the Workout Summary immediately.

Pause, Reset or Switch programs

See Console Operating Tips section for details, page 16

Maintenance

CAUTION – FOR SAFE OPERATION

Always inspect hardware prior to any exercise session. Look for loose hardware, loose pedals, loose cranks and frayed wires. Repair or replace any damaged or worn parts, tighten all loose hardware.

As part of Diamondback Fitness’ normal installation and set-up process, all pedal cranks must be tightened after 8 to 10 hours of initial riding to ensure parts are properly seated to axle. This is standard initial “break-in” service which must be performed after the first 8 to 10 hours of use. Un-tightened pedal cranks may become loose, causing damage which may void the warranty.

After training, always wipe down your unit. Perspiration that continuously settles on frame, pads or casing may eventually cause rust to the unit. Damage resulting from lack of proper maintenance will not be covered under warranty. To clean pads, use a mild soap and warm water. Dry with a clean towel.

If noises develop or malfunctions occur, contact your authorized Diamondback Fitness dealer.

Domestic Warranty Information

(Applies to all product sold and placed within the continental US, Alaska, Hawaii, and Puerto Rico only)

Effective: May 2008

Diamondback warrants its 900 model units to be free from defects in material and workmanship under normal use in home environments. Diamondback's obligation under this Warranty is limited to repair or replacement of any defective part without charge through an authorized service agent to the original purchaser with the following parameters:

Who is covered:

The Warranty is extended to the individual or legal entity whose name appears on the Warranty registration card filed with Diamondback and may not be transferred to any other individual or legal entity.

To obtain service:

To obtain service you must contact your authorized Diamondback Fitness dealer. Your dealer is also your authorized service agent. An authorized service agent must diagnose your unit in order to determine Warranty claims/issues.

Sales where the unit is delivered unassembled (in a carton) to the end user (e.g. mail order or Internet sales) without a service contract purchased through the dealer voids the Warranty.

Warranty Registration:

Warranty commitments are valid only with a completed Warranty card that is returned within 15 days from the date of purchase and includes the product serial number. Registration is available at www.diamondbackfitness.com.

Proof of purchase from Diamondback's authorized dealer will be required if the Warranty card is not registered prior to any consideration of Warranty claim.

What is covered

Home use only	Maximum usage: 14 hours per week.
Frame:	Lifetime limited Warranty, covers defects in welds, materials, and workmanship.
Brake:	Lifetime limited Warranty
Parts & Electronics:	3 Years
Labor:	1 Year

Warranty voided if:

The Warranty does not apply to any failure of the product, or any parts of the product, due to: assembly errors, alterations, modifications, misuse, abuse, accident, improper maintenance, or if the serial number on the product has been removed, altered or defaced. Assembly errors include but are not limited to:

- Damaged wire harness.
- Stripped crank arms and/or pedals.
- Bolts used in the wrong location.

Parts & Service:

Contact the authorized Diamondback dealer where unit as originally purchased. If you have moved, or

Domestic Warranty Information (Continued)

that retailer is unavailable, use our dealer locator at www.diamondbackfitness.com to help find another authorized dealer.

Diamondback is not responsible for arranging Warranty service and/or honoring extended warranties provided by dealers.

Exclusions:

Warranty is void if the 900 Model units is placed in a commercial or light commercial environment, such as health club, school, or correctional facility.

Additional Rights:

This Warranty is expressly in lieu of all other warranties, and any implied warranties of merchantability or fitness for a particular purpose created hereby, are limited to the same duration as the express Warranty herein. Raleigh America, Inc. shall not be liable for any incidental or consequential damages. Some states do not allow the exclusion or limitations of implied warranties, incidental or consequential, so the above limitations and exclusions may not apply to you.

Retailers and wholesale outlets for Raleigh America, Inc. products are not authorized to modify this Warranty in any way.

This Warranty gives the original owner specific legal rights. Other additional rights may vary from state to state.

Diamondback Fitness
 c/o Raleigh America, Inc.
 6004 S. 190th Street, Suite 101
 Kent, WA 98032
 Ph: 800.776.7642

Notes

Notes



Notes

Warranty Card



IMPORTANT! IMPORTANT! IMPORTANT! IMPORTANT!

Warranty card must be completed and returned to Diamondback within 15 days of purchase. Failure to comply may void manufacturer's Warranty. Or, you may register your product at www.diamondbackfitness.com.

Your Name: _____

Address: _____

City: _____ State: _____ Zip: _____

Daytime phone No.: _____ Evening phone No.: _____

Dealer Store Name: _____

Address: _____

City: _____ State: _____ Zip: _____

Model: _____ Serial No.: _____

Purchase Date: _____

Environment Unit Placed:

Home Light Institutional, i.e. Hotel, Business Center...

Mail Completed Form To:

Diamondback Fitness - Warranty Card
 c/o Raleigh America, Inc.
 6004 S. 190th Street, Suite 101
 Kent, WA 98032
 Ph: 800.776.7642