



**DIAMONDBACK**  
*Fitness*

***APEX Ic8***  
***INDOOR CYCLE OWNER'S MANUAL***



Thank you for purchasing this Apex Ic8 Indoor Cycle.

This product is 100% supported by Diamondback Fitness.

Please make sure all components are included with this product and that it arrived in good condition.

For assistance or questions please call Diamondback Fitness at

**800-776-7642**

or email us at

***customerservice@diamondbackfitness.com***

# APEX Ic8 Owner's Manual

**SAVE THIS OPERATING INSTRUCTIONS MANUAL FOR YOUR REFERENCE.**

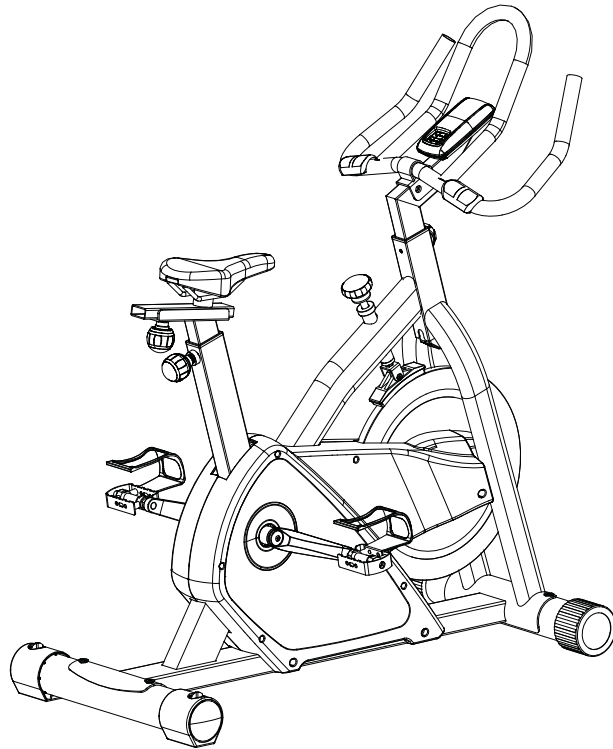

## **APEX Ic8** Computer Controlled Indoor Cycle

Release v.1 (10/2011)

## TABLE OF CONTENTS

THANK YOU - Inside Front Cover	
INTRODUCTION	3
SAFETY INSTRUCTIONS & WARNINGS	4
CARTON CONTENTS	7
ASSEMBLY INSTRUCTIONS	8
WORKOUT GUIDELINES	12
WORKOUT QUALITY AND QUANTITY	17
CONSOLE OVERVIEW & GENERAL NOTES	18
CONSOLE KEYPAD FUNCTION	20
CONSOLE OPERATION AND FEATURES	21
PROGRAM CATEGORIES	23
MAINTENANCE	30
WARRANTY INFORMATION	32
PURCHASER'S REFERENCE INFORMATION	34
WARRANTY REGISTRATION CARD	35

## INTRODUCTION

Congratulations on the purchase of your new APEX Ic8 Computer-Controlled Indoor Cycle from Diamondback Fitness. You have made a smart choice and are about to enjoy one of the most effective and technically-advanced methods of cardio-vascular exercise available today.

Founded in 1991 as an off-shoot of the legendary bicycle division, Diamondback Fitness was in many ways a complimentary addition to the Diamondback brand. One might even say this extension grew as a natural evolution from classic outdoor bicycle usage toward indoor-based cycling and cross training. It turns out many fitness enthusiasts were searching for ways to maintain conditioning during times of inclement weather or were simply looking for new and different crosstraining options.

This trend still continues today, twenty years later, as the strong Diamondback brand resonates with both the boomers who grew up with the bicycles, as well as the younger generations riding them today.

Diamondback Fitness continues to build upon this legendary brand identity by offering the cardio enthusiast a full line of upright bikes, recumbents, indoor cycles, and elliptical trainers that offer great value, high quality and intuitive & visually-pleasing design. Let's just say, we are already planning our next twenty years.

### **Diamondback Fitness**

**6004 South 190th Street Suite 101 Kent WA 98032 Ph. 1.800.776.7642 Fax: 1.800.776.2073**

For more information or questions regarding your equipment, please visit our website at [www.diamondbackfitness.com](http://www.diamondbackfitness.com)

## SAFETY INSTRUCTIONS & WARNINGS

Every piece of Diamondback Fitness equipment is built for maximum safety and meets or exceeds all applicable domestic and international standards. However, certain precautions must be taken when operating any exercise equipment.

***NOTE: Please read the entire owner's manual before operating the APEX Ic8.***

### CAUTION - FOR SAFE OPERATION

- Keep your hands and feet away from all moving parts and pinch points.
- If you have a history of heart disease, high blood pressure, diabetes, chronic respiratory diseases, elevated cholesterol, or if you smoke cigarettes or experience any other chronic diseases or physical complaints, consult with a physician before beginning any exercise program.
- If overweight, or above the age of 35, consult with your physician before beginning any exercise program.
- Pregnant women should consult with their physician before beginning an exercise program.
- If you experience dizziness, nausea, chest pains or other abnormal symptoms during exercise, stop the exercise session immediately and consult your physician.
- Consume water before, during and after each exercise session.

## SAFETY INSTRUCTIONS & WARNINGS

### WARNINGS - TO REDUCE RISK OF INJURY TO YOURSELF OR OTHERS

- To ensure proper functioning of your unit, do not install attachments or accessories not provided or recommended by Diamondback Fitness.
- Always wear proper clothing and shoes when exercising.
- User weight is not to exceed 300 pounds (147.4 Kg) for the APEX Ic8.
- Keep children away from the unit. Hands and feet may become entangled with the moving parts and could result in serious injury.
- Place the unit in an area that will meet minimum clearance requirements:
  - front & sides = 24 inches
  - rear = 12 inches.
- The unit is intended for indoor use only.
- Place the unit on a solid, level surface. Always adjust the leveling feet before using to ensure stability.
- Ensure all adjustment knobs and levers are fastened securely before using the unit and after making an adjustment.
- Use the handlebars when stepping on and off the unit.
- The unit is heavy. Do not attempt to move alone.
- Never operate the unit if it is damaged or broken. Contact your local authorized Diamondback Fitness Dealer for service.
- Always unplug the unit from the power source before moving or servicing.
- Do not remove the covers or other components. Only Authorized Diamondback Fitness Dealers or Authorized Technicians should perform service on the unit.

## SAFETY INSTRUCTIONS & WARNINGS

### *Assembly of Technical Items*

Assembly of all Diamondback Fitness products should be performed by a Diamondback Fitness Dealer or Authorized Technician. A significant amount of technical knowledge is required for the safe and complete assembly of the unit. Many retailers will offer delivery and assembly as part of the sales agreement. If this unit was sold unassembled (in the carton) and you do not feel you can perform the assembly successfully, please call the dealer for service. Service calls for improper assembly are not covered by the Warranty Policy and any associated charges will be the responsibility of the owner.

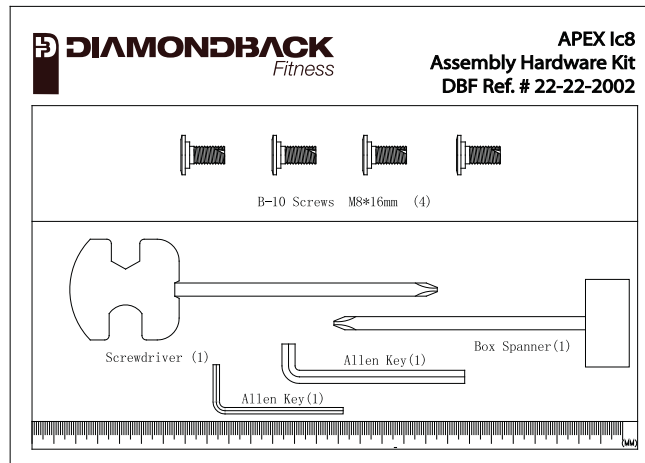



# APEX Ic8 Owner's Manual

## CARTON CONTENTS

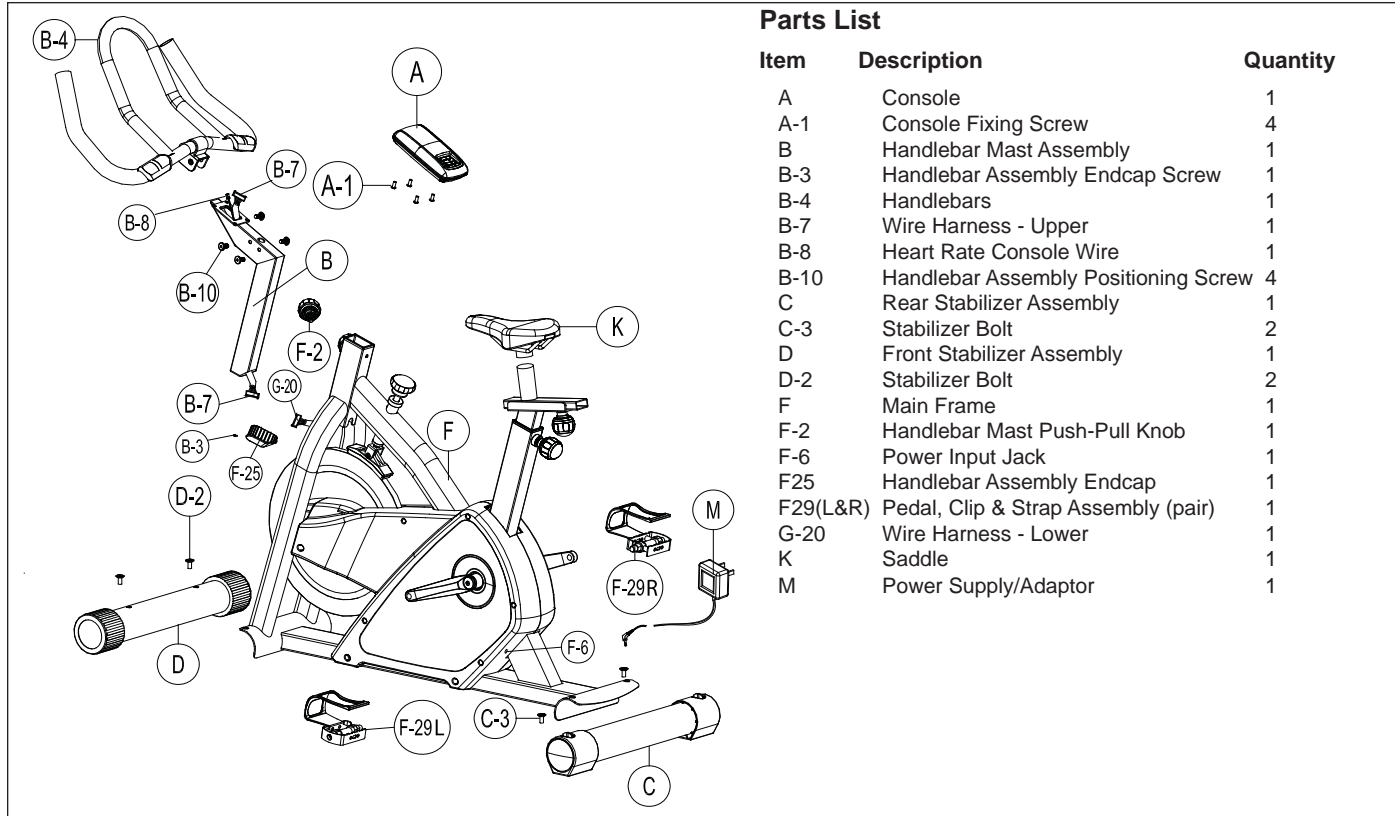

### Parts List

Item	Description	Quantity
A	Console	1
A-1	Console Fixing Screw	4
B	Handlebar Mast Assembly	1
B-3	Handlebar Assembly Endcap Screw	1
B-4	Handlebars	1
B-7	Wire Harness - Upper	1
B-8	Heart Rate Console Wire	1
B-10	Handlebar Assembly Positioning Screw	4
C	Rear Stabilizer Assembly	1
C-3	Stabilizer Bolt	2
D	Front Stabilizer Assembly	1
D-2	Stabilizer Bolt	2
F	Main Frame	1
F-2	Handlebar Mast Push-Pull Knob	1
F-6	Power Input Jack	1
F-25	Handlebar Assembly Endcap	1
F29(L&R)	Pedal, Clip & Strap Assembly (pair)	1
G-20	Wire Harness - Lower	1
K	Saddle	1
M	Power Supply/Adaptor	1

## ASSEMBLY INSTRUCTIONS

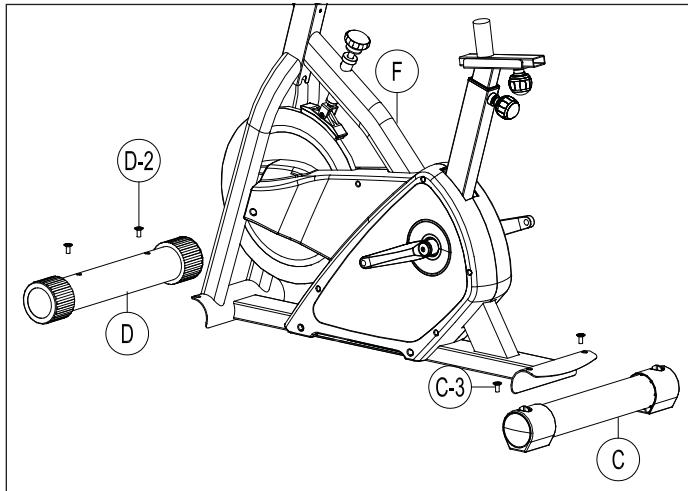

- Unpack the APEX Ic8 from the carton.
- Verify the carton contains all parts from the list.
- Install the front stabilizer (D) by removing the Two 2 bolts (D-2) from the Stabilizer (D), then position in place on the frame (F) and reinstall the two 2 bolts (D-2) and tighten into place.
- Install the rear stabilizer (C) by removing the Two 2 bolts (C-3) from the Stabilizer (C), then position on the frame (F) and reinstall the two 2 bolts (C-3) and tighten into place.

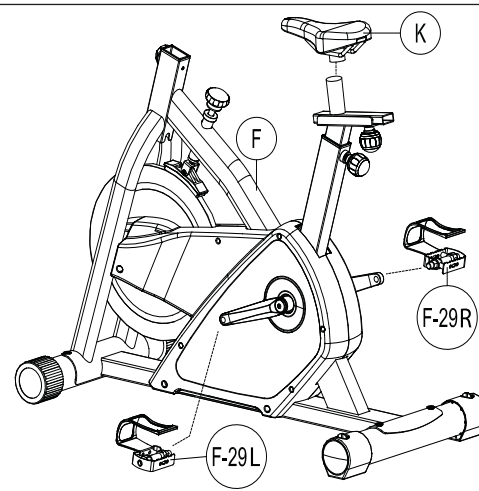

- Install the saddle (K) onto the seat post and tighten with the included wrench.
- Install the pedals (F29-L & F29-R) onto the cranks by threading the left pedal by hand (marked with an "L") into the left crank with a **counter-clockwise rotation**. Do not cross-thread the cranks/pedals. The pedal must be tight and installed completely to prevent damage to the cranks.
- Repeat the pedal installation steps for the right side, noting that the pedal will thread into the right crank with a **clockwise rotation**.

## ASSEMBLY INSTRUCTIONS

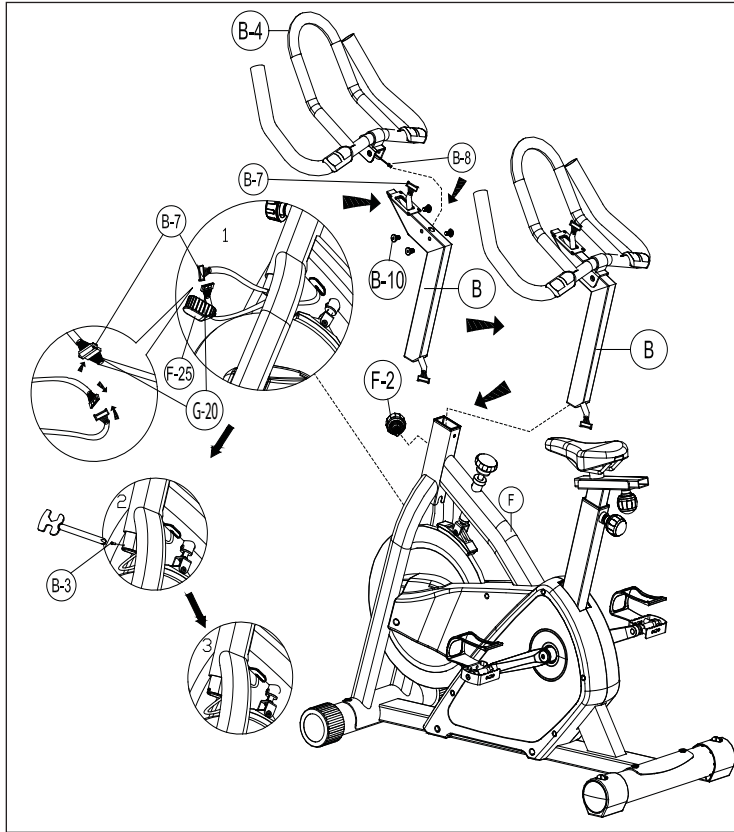

- Install the handlebars (B-4) by placing them on top of the console mast (B) close to the mounting position and hand feed the Heart Rate Wires (B-8) through the round hole on top of the handlebar mast (B) and up and out of the console mounting bracket next to the upper wire harness (B-7).
- Feed the excess wire into the hole while aligning the handlebars into position with the 4 holes on the handlebar mast (B). Install the 4 bolts (B-10) by hand and tighten into place after making sure not to pinch the heart rate wires (B-8).
- Place the handlebar mast (B) into the frame (F). Install the handlebar mast push-pull locking pin (F-2), position the bars at the lowest setting so the mast sticks out the bottom.
- Remove the plastic handlebar assembly endcap (F-25) by removing the screw (B-3).
- Connect the upper wire harness (B-7) to the lower wire harness (G-20). Make sure the connection is firm and feed excess cable into frame and mast.
- Reinstall the plastic handlebar assembly endcap (F25) and reinstall the screw (B-3).

## ASSEMBLY INSTRUCTIONS

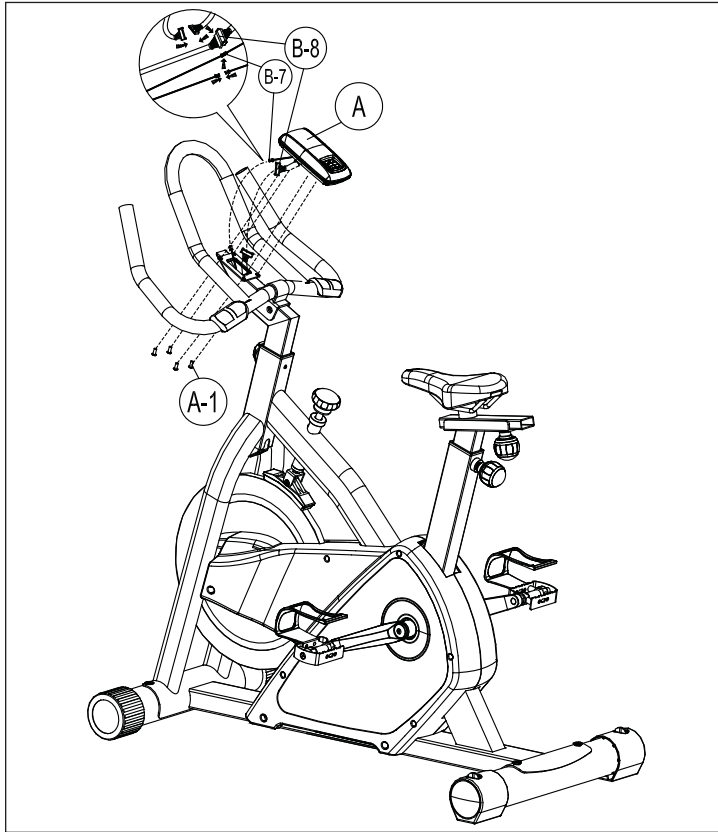

- Remove the four console fixing screws (A-1) from the back of the Console (A) and set them aside.
- Plug the upper wire harness connector (B-8) and the Heart Rate Console Wire (B-7) into the matching connectors on the back of the Console (A). Make sure both connections are firmly connected and click into position.
- Position the console above the mounting plate located on the Handlebar Mast (B). Be careful feeding excess wires into the opening on the Handlebar Mast (B) while positioning the console.
- Reinstall the four (4) fixing screws (A-1) through the underside of the plate and into the console. Tighten the four screws only after all four have been started by hand.

## ASSEMBLY INSTRUCTIONS

### FINAL INSTALLATION & SET UP

- Moving and Positioning the Unit. Move the APEX Ic8 into the desired final position by carefully raising the rear end of the unit until the wheels located on the front stabilizer contact the floor. Leave room around the unit for safe operation and sufficient air flow.
- Leveling the unit. Level the unit by turning the leveling knob right or left until the unit is level.
- Plug one end of the power adaptor (M) into a 120V power source. Plug the opposite end into the power input jack found on the back end of the plastic housing near the rear stabilizer.

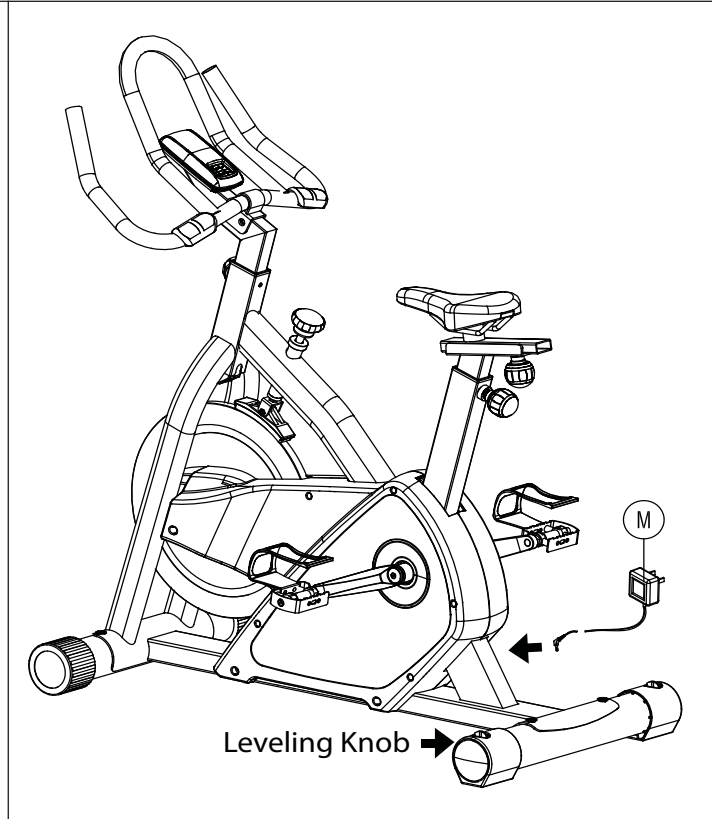

**Good health is an exercise in common sense.**

In the study titled, *“The Surgeon General’s Call To Action To Prevent and Decrease Overweight and Obesity”*, the Surgeon General indicates that 61% of American adults are either overweight or obese. The study indicates that being overweight increases the risk of health problems, such as heart disease, certain types of cancer, type 2 diabetes among other afflictions.

The Surgeon General’s Healthy weight advice for consumers is:

- Aim for a healthy weight: Find your Body Mass Index (BMI) on the chart below.
- Be active: Keep physically active to balance the calories you consume.
- Eat well: Select sensible portion sizes.

Body Mass Index; BMI = (weight (lb) ÷ height<sup>2</sup> (in)) x 703

		Weight in Pounds													
		120	130	140	150	160	170	180	190	200	210	220	230	240	250
Height in Feet and Inches	4'6"	29	31	34	36	39	41	43	46	48	51	53	56	58	60
	4'8"	27	29	31	34	36	38	40	43	45	47	49	52	54	56
	4'10"	25	27	29	31	34	36	38	40	42	44	46	48	50	52
	5'0"	23	25	27	29	31	33	35	37	39	41	43	45	47	49
	5'2"	22	24	26	27	29	31	33	35	37	38	40	42	44	46
	5'4"	21	22	24	26	28	29	31	33	34	36	38	40	41	43
	5'6"	19	21	23	24	26	27	29	31	32	34	36	37	39	40
	5'8"	18	20	21	23	24	26	27	29	30	32	34	35	37	38
	5'10"	17	19	20	22	23	24	26	27	29	30	32	33	35	36
	6'0"	16	18	19	20	22	23	24	26	27	28	30	31	33	34
	6'2"	15	17	18	19	21	22	23	24	26	27	28	30	31	32
	6'4"	15	16	17	18	20	21	22	23	24	26	27	28	29	30
	6'6"	14	15	16	17	19	20	21	22	23	24	25	27	28	29
	6'8"	13	14	15	17	18	19	20	21	22	23	24	25	26	28

- Healthy Weight
- Overweight
- Obese

Note: Chart applies to adults aged 20 years and older

## WORKOUT GUIDELINES

**Heart rate is an important key to your exercise.**

The Surgeon General also released a report on physical activity and health. This report dictates that exercise and fitness are beneficial for a person’s health and reiterated the need for exercise as a key component of disease prevention and healthier living.

If exercise intensity is too low or too high, no gains will be made in fitness. If the intensity is too low, the stress levels are ineffective. If the intensity is too high, injury or fatigue may set your exercise program back as you try to recover.

The best way to determine exercise intensity is to accurately count your pulse during exercise. Your heart rate can easily be determined by counting your pulse at the chest, wrist or at the carotid artery on your neck. It is difficult to count your own pulse during exercise, mainly because you cannot count fast enough to record an accurate rate. This Diamondback Fitness 510lc is equipped with contact heart rate sensors.

### Typical Target Zone Exercise Patterns for 35 year-old

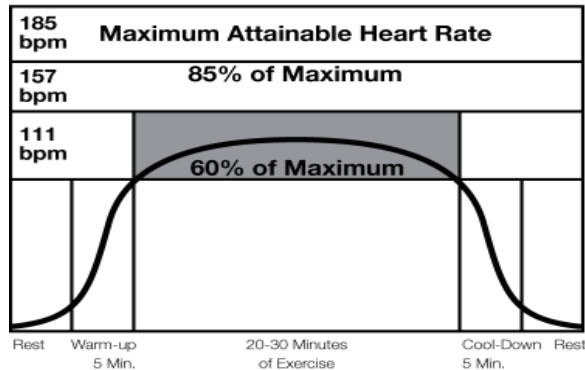



## WORKOUT GUIDELINES

### Calculated Maximum Heart Rate & Target Training Zone

Your calculated target heart rate, or the ideal intensity needed to improve cardiovascular fitness, depends primarily upon your age rather than your current state of fitness. If the exercise intensity is too low or too high, only modest gains will be made in strength and cardio-vascular fitness. A workout at a very low intensity will not offer maximum benefits. Conversely, if the workout intensity is too high, injury or fatigue may slow the progression of your exercise goals as the body attempts to recover.

**Note:** *It is most effective to train at a heart rate between 60% and 85% of your maximum heart rate. Maximum heart rate is calculated as a percentage of your maximum heart rate (estimated as 220 beats-per-minute minus your age).*

To calculate your maximum heart rate and find the appropriate target training zone, use the following formulas. For example, the following estimation would be relevant for a 35 year-old user:

$$\begin{aligned} 220 - \text{Age} &= \text{Maximum Heart Rate} & (220 - 35 &= 185) \\ 60\% \text{ of Maximum Heart Rate} & & (60\% \times 185 &= 111\text{bpm}) \\ 85\% \text{ of Maximum Heart Rate} & & (85\% \times 185 &= 157\text{bpm}) \end{aligned}$$

Based on these calculations, the recommended heart rate training zone for this user would be between 111 Bpm – 157 Bpm.

## WORKOUT GUIDELINES

The graph below displays the recommended heart rate training zone for users twenty years of age to seventy-five years of age.

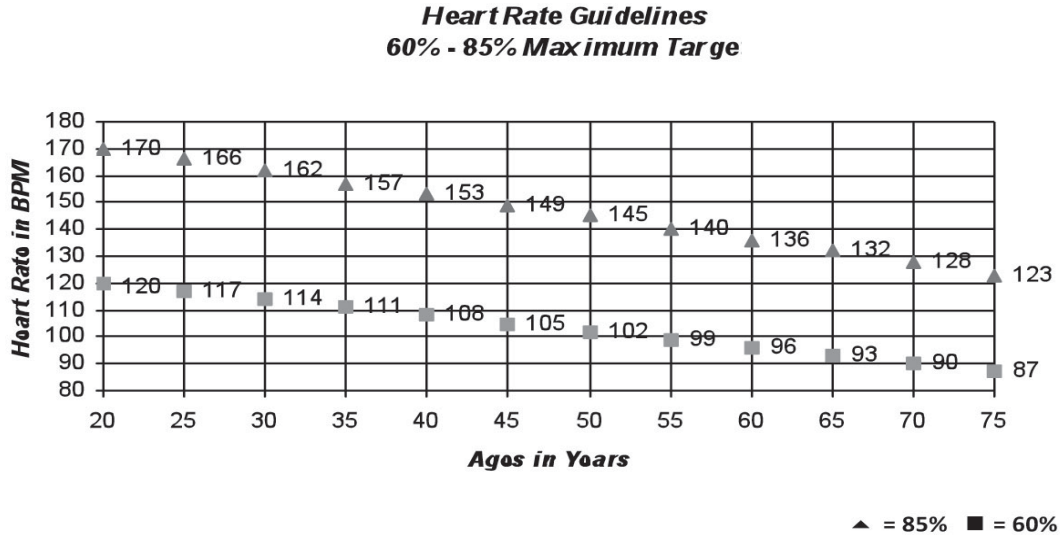

## WORKOUT GUIDELINES

### WORKOUT QUALITY AND QUANTITY

It is recommended that you accumulate at least 30 minutes of physical activity most days of the week. Physical activity should be initiated slowly and the intensity should be increased gradually. You should select activities that you enjoy and can fit into your daily life. Having Diamondback Fitness equipment at home certainly gives you the comfortable and convenient workout you want.

The American College of Sports Medicine makes the following recommendations for the quantity and quality of training for developing and maintaining cardio respiratory fitness in healthy adults:

- An activity that uses large muscle groups, maintained continuously, and is rhythmical and aerobic in nature.
- Duration: 20 to 60 minutes of continuous aerobic activity, including a warm-up and cool-down period, for each exercise session.
- Frequency: 3 to 5 times per week.
- Intensity: 60% to 85% of maximum heart rate.

In addition to aerobic exercise, strength training of moderate intensity twice per week is recommended. Women especially may benefit from weight-bearing exercises. Select activities you enjoy and can fit into daily life. Having Diamondback Fitness equipment at home offers you the opportunity to work out without going to the gym.

### Get a smart start on exercising

Anyone over the age of 35, as well as, younger persons who are overweight, should check with his/her physician before beginning any type of exercise program. People who have diabetes or high blood pressure, a family history of heart disease, high cholesterol or have led a sedentary lifestyle should protect themselves with a medical check-up and a stress test, preferably administered during exercise by a health care professional.

- Always stretch before your workout to loosen muscles, and afterward to cool down.
- The first few minutes of your workout should be devoted to warming up muscles before a vigorous workout, and building your heart rate slowly.
- After your aerobic workout of about 24-32 minutes, spend 10 minutes gradually reducing your heart rate with a lower resistance level.

***NOTE: Start slow, with intensity low until you build up endurance and strength. Always consult your physician before beginning any exercise program.***

## CONSOLE

### CONSOLE OVERVIEW & GENERAL NOTES

A primary feature of the APEX Ic8 is the ability to control and monitor the user's workout program via the brilliant LCD console. At any time, the user may view their speed, RPM, elapsed time, distance, Watts, calories and pulse rate.

Connect the included power supply/adaptor to a 120V power source. Plug the opposite end into the APEX Ic8 power input jack found near the ground at the rear of the machine. To avoid damage and danger, use only the power supply/adaptor that was designed for the APEX Ic8.

To provide power to the display console and computer, begin pedaling at a rate exceeding fifteen (15) revolutions per minute.

To conserve energy, the console will automatically power down after sixty (60) seconds of inactivity.



## CONSOLE



**Matrix Display.** The Matrix Display is comprised of a 128 segments arranged in sixteen (16) horizontal columns, eight (8) rows high. The height of the lit vertical stack represents the current resistance level. The flashing column will display the progress in the current program. Each column equals 1/16th of the total program run time.



**Elapsed Time.** The Time display field begins to count up as soon as the program is launched. The clock will accumulate time up to 99 minutes, 59 seconds.



**Speed.** Speed is displayed in miles-per-hour from 0.0 to 99.9. SPEED and RPM will alternate every four (4) seconds as they are displayed in the same field.



**RPM.** RPM, or revolutions per minute, is the number of complete pedal rotations a single pedal makes in sixty (60) seconds. The displayed range is 0 to 999. RPM and SPEED will alternate every four (4) seconds as they are displayed in the same field.



**Distance.** Distance is displayed in miles and will begin to accumulate when the program is launched. The range of the display will be from 0 minutes, 1 second to 99 minutes, 60 seconds.



**Heart Rate.** The pulse or heart rate will be displayed in beats per minute. The contact Heart Rate sensors located on the handlebars must receive a heart rate between 30 BPM and 240 BPM to register. When a heart rate is detected by the console, the heart symbol will flash.

## CONSOLE



**Calories.** The total calories burned since the program launch will be displayed in the Calories field. Speed, Resistance and Time are all factors that determine the rate at which the calories are burned.



**Watts.** Watts is a unit of power that is often tracked during exercise routines to represent the amount of “work” being generated. While the program is operating, the total Watts generated by the user will be displayed. If operating a program with a Watt target control, the circle to the left of the Watt value will flash to indicate that the user is generating a Watt value close to the preset target. The flashing arrows will indicate that the Watt value is above or below the target.

## CONSOLE KEYPAD FUNCTION

This APEX Ic8 keypad consists of six keys that are used to control all functions of the console programming.



**Fit Test Key.** The FIT TEST key will launch the Fitness Test program.



**Enter Key.** The ENTER key confirms user setting and allow the user to select program options during the program and user setup modes.



**Reset Key.** Pressing the RESET key will stop all programs and return the console to the main screen.



**Start-Stop Key.** Pressing the START-STOP at any time will pause all functions of the unit. Pressing the START-STOP key again will restart console and return the display to the main screen.

## CONSOLE



Up & Down Arrow Keys. The UP and DOWN arrow keys allow the user to adjust the on-screen values in the program setup mode. While operating the Heart Rate Control program, the arrow keys will adjust the target heart rate. During all other programs, the arrow keys will increase or decrease the resistance.

### CONSOLE OPERATION AND FEATURES

#### Power Up

Provide power to the unit by pedaling at a rate of fifteen (15) revolutions per minute or greater. The console will light all segments of the LCD display for two seconds and a short beep will sound.

#### Reset

You can reset all of the values back to zero by holding the START/STOP key down for 3 seconds. This action will erase all save data, including user-defined workout profiles.

#### Program Selection Mode

After powering up, the console will enter the main screen or program selection mode, where the program titles will be flashing. Use the UP or DOWN arrow keys to highlight the desired program and press the ENTER key launch the program setup mode for the selection.

#### Program Options

The APEX Ic8 offers four program categories: MANUAL, H.R.C. (Heart Rate Control), PROGRAM (Pre-programmed Profiles) and USER (User Defined/Custom). Within these categories, H.R.C and PROGRAM offer several options (see the chart below). When the unit is powered on, the small cluster of program titles on the LCD display will flash, prompting the user to make a selection.

## CONSOLE

<i>Program Mode</i>	<i>Qty</i>	<i>On-Screen Name</i>
Manual	1	N/A; Profile Displayed
Heart Rate Control	4	50%, 75%, 90% THR
Profiles (Pre-programed)	8	P1 through P8
User Defined / Custom	1	N/A; Profile Displayed

### QuickStart

If the START-STOP key is pressed while the main screen is displayed, the console will QuickStart the Manual program, bypassing all user setting adjustments and accept the default values.

### Change Programs

While in program run mode, to change from one category or program to another, pressing the START-STOP key will pause the current program. Press RESET to return to the program selection mode (See section titles Program Selection Mode).



## PROGRAM CATEGORIES

### Manual Program



**Overview.** The Manual category contains only one default profile. The profile is set from the factory as a flat line across the Matrix Display to represent a workout that is at the lowest resistance. The user will manually adjust the resistance level during the workout. The selected resistance setting will carry over to the next segment and continue until the user alters the resistance.

**Launch.** If the user wishes to accept the default setting, pressing the START-STOP key will immediately launch the program. Adjustments to the resistance are made via the UP and DOWN arrow keys.

**Custom Targets.** If the user would like to customize the program matrix such as the workout Time period or incorporate Distance, Calorie or Watt generation targets, pressing the START-STOP key after the program begins will pause the program and allow the user to adjust these values.

Each time the ENTER key is pressed, the console will scroll through the available settings; **TIME → DISTANCE → CALORIES → WATTS → PULSE → TIME**. The user may adjust any number of these targets or accept the current/default values and press the START-STOP key to launch the program.

**Workout Time Setting.** Once the Manual program has been selected, pressing the ENTER key will launch the setup mode. TIME will flash on the console display with the default value of twenty-four (24) minutes. Increase and decrease the workout time setting via the UP and DOWN arrow keys. The range of values is 1 minute to 99 minutes, inclusive.

During the program, the displayed Time value will count down from the user's target. The beeper will sound when this target has been achieved.

You may exit the setup mode and launch the Manual program at any time by pressing the START-STOP key. To continue with the setup mode and adjust the Distance setting, press the ENTER key.

## PROGRAM CATEGORIES

**Distance Target Setting.** The Distance value will begin to flash. Adjust the desired distance target to a value within the range of 0.1 to 99.9 miles via the UP and DOWN arrow keys.

During the program, the displayed distance value will count down from the user's target. The beeper will sound when this target has been achieved.

You may exit the setup mode and launch the Manual program at any time by pressing the START-STOP key. To continue with the setup mode and adjust the Calorie setting, press the ENTER key.

**Calorie Target Setting.** The Calorie value will begin to flash. Adjust the desired calorie target to a value within the range of 10 to 999 via the UP and DOWN arrow keys.

During the program, the displayed calories value will count down from the user's target. The beeper will sound when this target has been achieved.

You may exit the setup mode and launch the Manual program at any time by pressing the START-STOP key. To continue with the setup mode and adjust the Watts setting, press the ENTER key.

**Watts Target Setting.** The Watts value will begin to flash. Adjust the desired Watt generation target to a value within the range of 10 to 350. Press ENTER to adjust the Watts generation target.

During the program, a graph consisting of an Up Arrow, a Down Arrow and a Circle between them will indicate the user's current status with regard to the preset Watt target. If the Watts being generated are below the target, the Down arrow will flash to indicate that the user is not generating enough Watts. The user should increase their RPM to maintain the Watts target. If the situation continues for more than three (3) minutes, the monitor will give six beeps, switch itself off, and reset the Watt value back to zero. A flashing circle will indicate that the Watts target is being achieved.

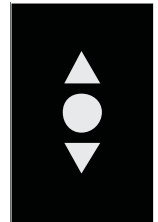

You may exit the setup mode and launch the Manual program at any time by pressing the START-STOP key. To continue with the setup mode and adjust the Heart Rate setting, press the ENTER key.

## PROGRAM CATEGORIES

**Heart Rate Limit Setting.** The Pulse value will begin to flash. Adjust the desired pulse/heart rate target to a value within the range of 20 to 240 BPM via the UP and DOWN arrow keys. Press ENTER to continue scrolling through the setting loop, or press START-STOP to launch the program.

During the program, the console will beep to indicate that the user's heart rate is equal to or greater than the pulse/heart rate limit setting. The user should decrease their pedaling speed.

**Program Launch.** Press the START-STOP key to launch the program.

**Pause.** To pause the program, press the START-STOP key. To return to program run mode, press the START-STOP key again.

**Exit.** To exit the setup mode, press the RESET key at any time.

**Program End.** Press the START-STOP key twice to end the program and return to the main screen

### Programs (Pre-Programmed)



Overview . The Program category contains eight (8) pre-programmed workout profiles the user may choose from. Adjustments to the resistance level may still be made manually during the workout program via the UP and DOWN arrow keys.

To select the PROGRAM category, highlight the PROGRAM category in the main screen via the UP and DOWN arrow keys. Press ENTER to accept.

Course Profile Selection. Once the PROGRAM category has been selected from the main screen, the first of the available course profiles will post in brickyard. Scroll through the options until the desired profile is displayed. Adjust the resistance level via the UP and DOWN arrow keys, or press ENTER to select the profile as displayed.

**Launch.** Pressing the START-STOP key will immediately launch the program.

Adjustments to the resistance are made via the UP and DOWN arrow keys.

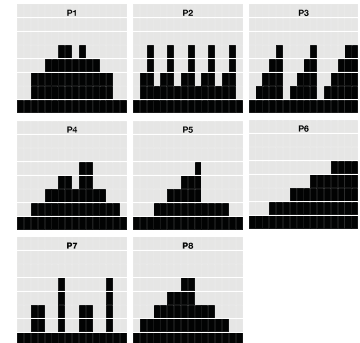

## PROGRAM CATEGORIES

**Custom Targets.** If the user would like to customize the current program parameter such as the workout Time period or incorporate Distance, Calorie or Time targets, pressing the ENTER key once will launch the program setup mode. Each time the ENTER key is pressed, the console will scroll through the available settings; TIME DISTANCE CALORIES PULSE TIME. The user may adjust any number of these targets or accept the current/default values and press the START-STOP key to immediately launch the program. The user may adjust any/all of these targets via the UP and DOWN arrow key. To accept the current setting and move to the next value, press the ENTER key.

**Program Launch.** Press the START-STOP key to launch the program.

**Pause.** To pause the program, press the START-STOP key. To return to program run mode, press the START-STOP key again.

**Exit.** To exit the setup mode, press the RESET key at any time.

**Program End.** Press the START-STOP key twice to end the program and return to the main screen.

### *User Program*

A rectangular button with a black background and white text that reads 'USER' in a bold, sans-serif font.

## **USER**

Overview . The USER category contains one program which allows the user to create a custom workout profile. This profile will be saved and accessible for future workout sessions. The user may still adjust the resistance level for the current time segment manually during the workout program via the UP and DOWN arrow keys.

To select the USER program, highlight the USER category in the main screen via the UP and DOWN arrow keys. Press ENTER to accept.

**Custom Profile.** When the USER program has been selected, the default or previously-saved course profile will post. The first column or time segment will flash, prompting the user to adjust the resistance via the UP and DOWN arrow keys. Make the desired adjustment to this segment and move to the next by pressing the ENTER key. Repeat these steps for all sixteen (16) segments.

## PROGRAM CATEGORIES

**Custom Targets.** To customize the program matrix such as the workout Time period or incorporate Distance, Calorie or Watt generation targets, press and hold the ENTER key for four (4) seconds, until the Time value begins to flash.

Each time the ENTER key is pressed, the console will scroll through the available settings; **TIME → DISTANCE → CALORIES → PULSE → TIME**. The user may adjust any/all of these targets via the UP and DOWN arrow keys. To accept the current setting and move to the next value, press the ENTER key.

**Program Launch.** Press the START-STOP key to launch the program.

**Pause.** To pause the program, press the START-STOP key. To return to program run mode, press the START-STOP key again.

**Exit.** To exit the setup mode, press the RESET key at any time.

**Program End.** Press the START-STOP key twice to end the program and return to the main screen.

### ***H.R.C. (Heart Rate Control) Programs***

#### ***H.R.C.***

**Overview.** The HRC category contains four (4) programs which allow the user to select their desired heart rate target. The console will provide messaging and feedback while automatically increasing or decreasing the pedaling resistance to maintain the specified heart rate. This is the definition of heart rate control. The console will increase the resistance one level every thirty (30) seconds if the user's heart rate is below the target. If the user's heart rate exceeds the target, the console will beep and the resistance will be reduced one level every fifteen (15) seconds until the user's heart rate falls below the target. To protect the user, the console will beep and shut down if the heart rate does not fall below the target after thirty (30) seconds have elapsed.

Three (3) of the programs target a percentage of the user's calculated maximum heart rate (see the section titled Calculated Maximum Heart Rate & Target Training Zone). The calculated maximum heart rate formula considers age to arrive at an upper threshold, or maximum. The user will be required to supply their age information for these programs to operate correctly. The computer then determines which heart rate represents 55%, 70% and 90% of the user's calculated maximum.

## PROGRAM CATEGORIES

The T.H.R. (Target Heart Rate) program differs from the percentage programs in that the user will set a numeric value for their targeted heart rate. Resistance will be controlled by the unit to help maintain the user's target pulse rate.

To select one of the H.R.C. program, highlight the H.R.C. category in the main screen via the UP and DOWN arrow keys. Press ENTER to accept.

**Program Setup.** After selecting the H.R.C. program category, "Age" will flash in the Matrix Display. Adjust the user's age via the UP and DOWN arrow keys, pressing ENTER to confirm.

**Program Selection.** " 55%" will flash in the Matrix Display. Scroll between the three (3) program options (55% 70% 90% ) via the UP and DOWN arrow keys. Confirm your selection by pressing the ENTER key.

**Custom Targets.** Once the program selection has been made, the Time value will begin flashing. Each time the ENTER key is pressed, the console will scroll through the available settings; TIME DISTANCE CALORIES PULSE TIME. The user may adjust any/all of these targets via the UP and DOWN arrow key. To accept the current setting and move to the next value, press the ENTER key.

**Program Launch.** Press the START-STOP key to launch the program.

**Pause.** To pause the program, press the START-STOP key. To return to program run mode, press the START-STOP key again.

**Exit.** To exit the setup mode, press the RESET key at any time.

**Program End.** Press the START-STOP key twice to end the program and return to the main screen.

### *Fitness Test*



The 510lc offers a pre-programmed test to provide a relative measurement of your body's ability to recover from a strenuous workout. The program will monitor the amount of time required for an elevated heart rate to return to normal. This comparison provides a fast, simple gauge of how fit you are. If you exercise regularly, you will see your fitness rating improve.

## PROGRAM CATEGORIES

The Fitness Test requires you to use the contact heart rate sensors on the handlebars. During the program, you must remain relaxed and hold the heart rate sensors.

To launch the Fitness Test program, press the FIT TEST button on the keypad. A one-minute timer will begin to count down. Only the countdown clock value and current heart rate will be displayed. When the program concludes, your relative fitness rating will be displayed in the Matrix Display. The returned values range from F1 to F6. See the chart above. This rating is only a guideline and not meant to serve as professional, medical or health information.

Press the START-STOP key to end the program and return to the main screen at any time.

Value	Rating
F1	Excellent Fitness
F2	Good
F3	Average
F4	Below Average
F5	Poor
F6	Very Poor

## MAINTENANCE

All Diamondback Fitness products are engineered for years of near-silent operation. Let noise be your first indication that a repair or adjustment is required. Please, discontinue use immediately and contact an Authorized Service Technician or Diamondback Fitness Dealer if an unusual noise, scraping, knocking, grinding or vibration is detected. Often, a minor issue will become a major repair if ignored and use is continued.

Prior to each workout, confirm that all adjustment levers and screws are tightened.

Tighten crank arms once per month. Loose cranks arms will become damaged and are not covered under the Warranty.

Your Diamondback Fitness product is manufactured of the most durable materials available. The plastics are molded of strong and chemical-resistant ABS and PVC. The frame is produced of high-tensile steel and protected with an industrial-grade, powder paint coating for the highest level of corrosion resistance. It is important to note however, that perspiration can be extremely corrosive if allowed to accumulate on the machine. After training, always wipe down the unit with a mild soap solution followed by a thorough drying with a clean towel. Locating a small spray bottle and towel near the unit will help ensure that your Diamondback Fitness equipment looks new for many years.

***NOTE: Perspiration is very corrosive and if allowed to remain on the machine, will cause discoloration, fading, rust and odors. Unfortunately, these conditions are not covered under the Warranty Policy.***



## WARRANTY INFORMATION

Diamondback Fitness warrants this unit to be free from defects in material and workmanship under normal use in the home environment. Diamondback Fitness's obligation under this warranty is limited to the repair or replacement of any defective part, provided free of charge through an Authorized Service Agent. This warranty is extended to the original purchaser. The following conditions apply:

### Who is Covered

The warranty is extended to the individual whose name appears on the Warranty Registration filed with Diamondback Fitness and may not be transferred to any other individual or legal entity. In the absence of a valid Warranty Registration, the original sales receipt will serve as satisfactory documentation of the valid warranty status.

### To Obtain Service

To obtain service, you must contact your Authorized Diamondback Fitness Dealer. Your dealer is also your Authorized Service Agent. An Authorized Service Agent must diagnose your unit to begin the warranty claim process.

### Warranty Registration

Warranty commitments are valid only with a completed Warranty Registration. Registration is available online at [www.diamondbackfitness.com](http://www.diamondbackfitness.com). Alternatively, a warranty card may be mailed to Diamondback Fitness. (See page 33)

### Proof of Purchase

Proof of purchase from a Diamondback Fitness Authorized Dealer will be required if the warranty card is not registered.

### What is Covered – For Interior Residential Use Only.

- Frame Limited lifetime warranty; covers defects in welds, materials, and workmanship (some exclusions apply).
- Brake Limited lifetime warranty
- Parts & Electronics 3 years
- Labor 1 year
- Wear Items 90 days

## WARRANTY INFORMATION

**Note:** *Limited lifetime refers to warranty coverage of the unit's expected service life, not the lifetime of the purchaser. The expected lifetime of this unit is five (5) years from the date of purchase although other factors can extend this period. Support and maintenance of the unit may become difficult or impossible after this period expires.*

### Voided Warranty

The warranty does not apply to any failure of the product or its components due to alterations or modifications, misuse and abuse, accidental damage, lack of maintenance or improper assembly. Improper assembly can be avoided if the unit is assembled by an authorized technician. Damage due to improper assembly is not covered by the warranty. Common assembly errors can include damaged wire harnesses, stripped screws and nuts, crank arms or damaged threads.

If the serial number has been removed, altered or defaced, the warranty for the affected unit is voided.

### Other Exclusions

The warranty for this unit is void if it is placed in commercial or light commercial environments such as health clubs, schools, hotels, condominium common areas, correctional facilities, or any other non-residential setting.

The warranty will not be honored if this unit is employed for commercial or rental purposes.

This unit is for indoor use only.

### Additional Rights

This Warranty is expressly in lieu of all other warranties, and any implied warranties of merchantability or fitness for a particular purpose created hereby, and are limited to the same duration as the express warranty herein. Diamondback Fitness shall not be liable for any incidental or consequential damages. Some states do not allow the exclusion or limitations of implied warranties, incidental or consequential, so the above limitations and exclusions may not apply to you.

Retailers and wholesale outlets for Diamondback Fitness products are not authorized to modify this warranty in any way.

This warranty gives the original owner specific legal rights. Other additional rights may vary from state to state.

## PARTS & SERVICE

Contact the Authorized Diamondback Fitness Dealer which originally sold the unit. If you have moved, or the retailer is unavailable, visit the Diamondback Fitness dealer locator site at [www.diamondbackfitness.com](http://www.diamondbackfitness.com) to help locate an alternate Authorized Dealer.

Diamondback Fitness is not responsible for securing warranty service and/or honoring extended warranties provided by dealers.

***NOTE: Authorized service technicians do not reside in all areas of the country. If you live beyond the reasonable service area of a metropolitan area, Diamondback Fitness may not be able to support the labor portion of the product warranty. Travel fees charged by technicians are not covered by the warranty.***

Although current at the time of this printing, specifications for this model may have changed in our continuing effort for improvement. Diamondback Fitness reserves the right to modify and improve the specifications of its products without prior notice

## PURCHASER'S REFERENCE INFORMATION

PLEASE RECORD DETAILS ASSOCIATED WITH THE PURCHASE OF YOUR APEX Ic8 BELOW. THIS INFORMATION WILL BE REQUIRED IN THE EVENT THE UNIT REQUIRES FUTURE SERVICE.

**\*ATTACH THE PURCHASE RECEIPT HERE:**

**Product Name:** APEX Ic8 Indoor Cycle

**Serial Number:** E \_\_\_\_\_

**Date Purchased:** \_\_\_\_\_

**Costco Store Address:** \_\_\_\_\_  
 \_\_\_\_\_

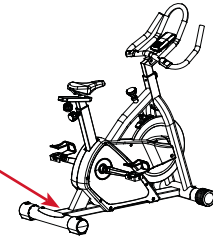
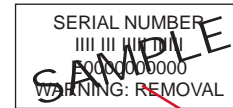

## Serial Number Location

**To Activate Warranty:** Register the unit at [www.diamondbackfitness.com](http://www.diamondbackfitness.com) OR complete the attached warranty card (see last page) and return it to Diamondback Fitness within 15 days of purchase. Failure to comply may limit or void the Manufacturer's warranty coverage.

Dealer Store N

**Shipping Materials:** Diamondback Fitness recommends that you retain the original packing materials (box and packing items) for future shipping needs.

**Warranty:** \_\_\_ Mailed \_\_\_ Online Date \_\_\_\_\_

# APEX Ic8 Owner's Manual

***Important! • Important! • Important! • Important! • Important!***

*The warranty card must be completed and returned to Diamondback Fitness within 15 days of purchase. Failure to comply may void the manufacturer's warranty. You may also register your product via the web at: [www.diamondbackfitness.com](http://www.diamondbackfitness.com)*

Your Name: \_\_\_\_\_

Address: \_\_\_\_\_

City: \_\_\_\_\_

State: \_\_\_\_\_

Zip: \_\_\_\_\_

Daytime phone No.: \_\_\_\_\_

Evening phone No.: \_\_\_\_\_

Dealer Store Name: \_\_\_\_\_

re Name: Address: \_\_\_\_\_

City: \_\_\_\_\_

State: \_\_\_\_\_

Zip: \_\_\_\_\_

**Model:** **APEX Ic8**

**Serial No.:** **E** \_\_\_\_\_

**Purchase Date:** \_\_\_\_\_

Mail completed warranty form to:  
Diamondback Fitness - Warranty Card, 6004 South 190th Street, Suite 101, Kent WA 98032





# APEX Ic8 Owner's Manual

---



DIAMONDBACKFITNESS.COM • 6004 S. 190TH STREET, SUITE 101 • KENT, WA 98032 • PH: 800.776.7642

©2012 DIAMONDBACK FITNESS

---